

AUTOMATION
TECHNOLOGY

RODLESS CYLINDERS

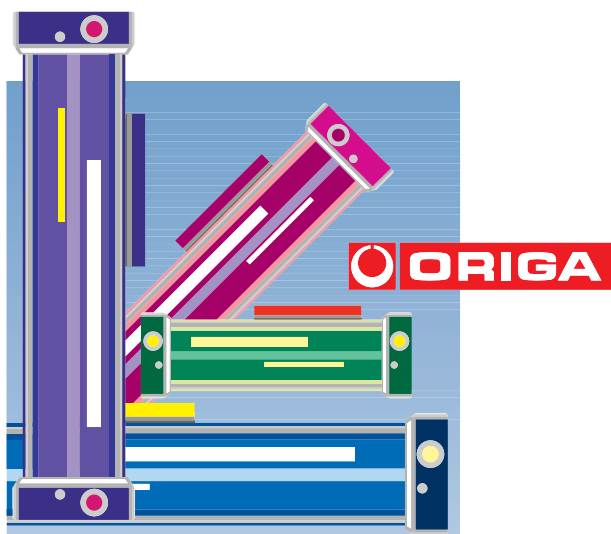

HOERBIGER

ORIGA

1. General Information

2. Application Data

3. Technical Data

4. Proximity Sensors

5. Spare Parts

6. Assembly Instructions

Introduction

Origa Corporation, the US operation of Hoerbiger International's Origa Division, is the principle manufacturer of rodless pneumatic cylinders for the United States, South American and Canadian markets.

As part of a global organization, Origa's world wide sales and service network is supported by manufacturing and assembly locations in Europe, Australia and Asia. The parent company, Hoerbiger International, is a world-wide manufacturer and developer of industrial products, including pneumatic and hydraulic automation components.

Origa is committed to developing the rodless cylinder technology with innovations that can facilitate greater penetration into the linear motion market. In particular, new developments have reduced or eliminated the need for additional support and secondary engineering associated with alternative systems.

Through market specialization Origa dominates the international market for rodless cylinders and has cultivated unparalleled expertise in their application. The company operates with an extensive distributor network, a worldwide sales force, and a complete application engineering staff dedicated to customer and technical services.

Origa strives to provide customers with products tailored to their needs, with consistent high quality and reliability. If you require further information or assistance, please complete the attached business reply card or contact us directly at any of the locations listed in section 1 page 1.1/7

The Pneumatic Rodless Cylinder

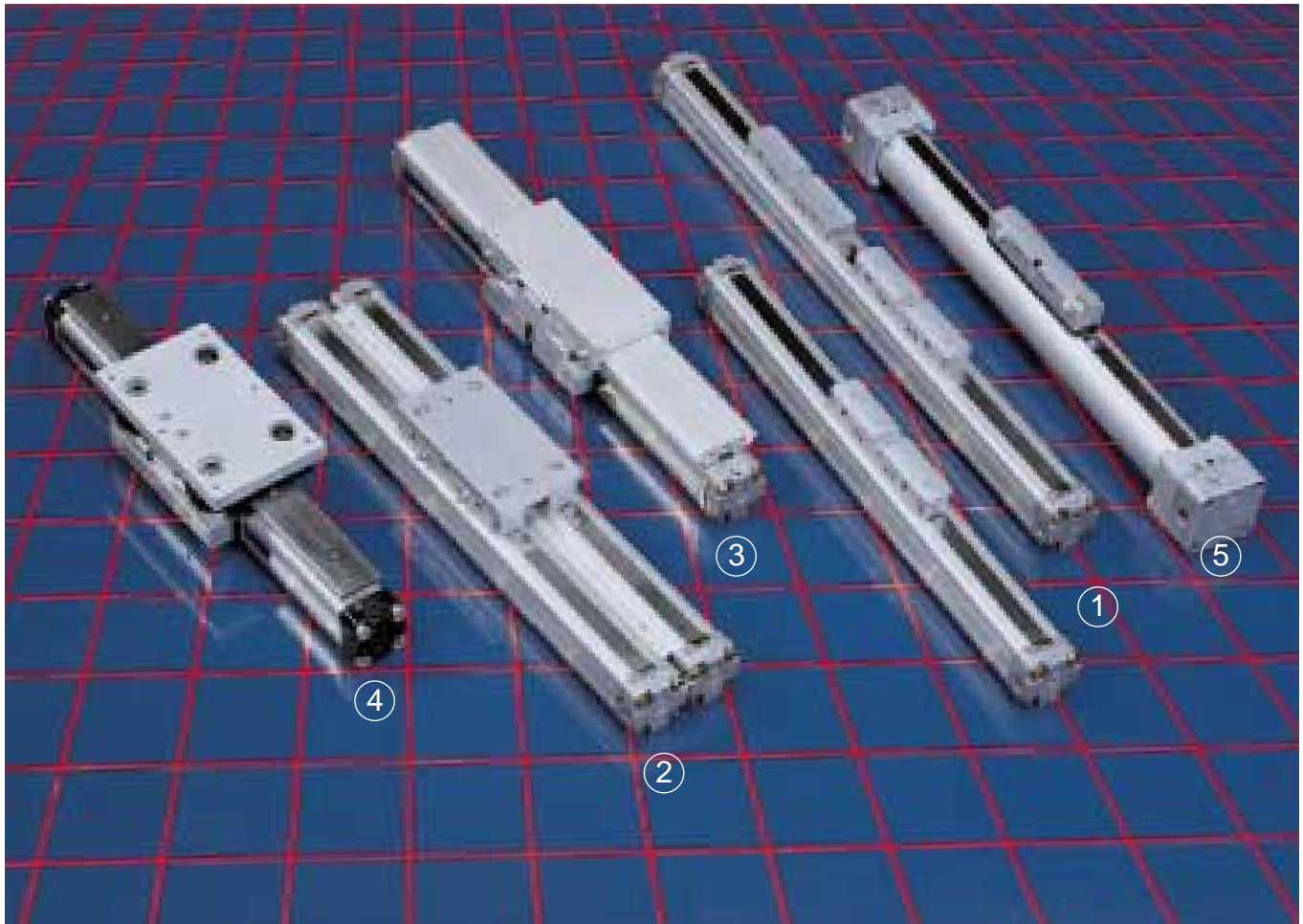

The following cylinder types are available:

1. **Series 2000 - Basic Cylinder**
Available in the following bore sizes: 10mm, 16mm, 25mm, 32mm, 40mm, 50mm
Single Piston and Double Piston configurations
2. **Series 2000 - Joint Clamp**
Available in the following bore sizes: 25mm, 32mm, 40mm, 50mm
Single Piston and Double Piston configurations
3. **Series 2000 - NR50** See OSP-P Series
Available in the following bore sizes: 16mm, 25mm, 32mm, 40mm, 50mm
Single Piston and Double Piston configurations
4. **Series 2000 - Powerguide™** See OSP-P Series
Available in the following bore sizes: 25mm, 32mm, 50mm
5. **Series P120 - Basic Cylinder**
Available in the following bore sizes: 40mm, 63mm, 80mm
Short and Long Piston configurations

The ORIGA Principle

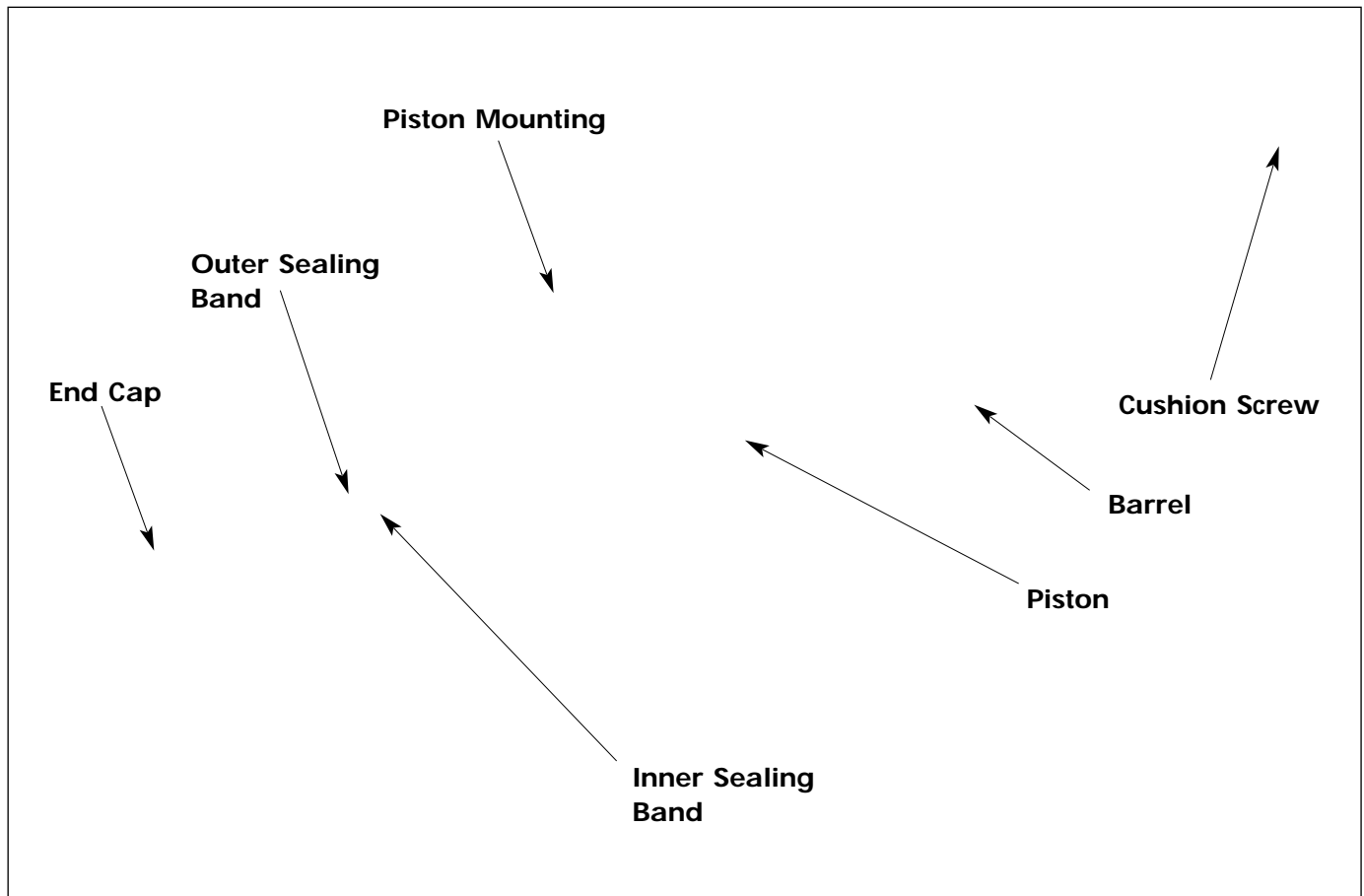

Features

1. The cylinder barrel of extruded anodized aluminum has a slot along its entire length. To provide rigidity the bore is eccentric to the outside diameter.
 2. A flexible hardened stainless steel inner band running the entire length of the bore and passing through the piston provides a near-zero-leakage metal to metal seal. An outer band of the same material acts as a cover over the slot preventing foreign particles from entering into the cylinders interior.
 3. The aluminum piston is fitted with synthetic bearing rings. The power transmission outward takes place through a positive, physical connection through the slot to the external piston mounting. This solid guide permits the acceptance of external forces and moments and minimizes frictional losses.
 4. The extensive experience in the development and production of rodless cylinders, as well as the use of high quality components and materials, ensure a very serviceable design lending itself to high operating safety and optimum performance.
 5. This unique design, using only 4 main components, makes ORIGA cylinders reliable in operation and simple to maintain, providing long trouble free service.
 6. ORIGA is the specialist in the rodless cylinder field. ORIGA has the largest range of bore diameters and can offer the longest stroke lengths with application oriented accessories for cost effective designs. ORIGA has experience in all conceivable areas of industry, attributable to the thousands of applications in which ORIGA rodless cylinders are used.
- The ORIGA system is protected by worldwide patents.

Technical Benefits

Design Options

ORIGA cylinders can be supplied as a basic model, or as a basic model with external guides depending on the application requirements.

Cylinder Mountings

Various types of piston mounting are available including one which allows the cylinder to be inverted under adverse operating conditions thus protecting the sealing bands. End mounting brackets and mid-section supports are also available.

Operating Pressure

Max. 120 P.S.I.

End Of Stroke Cushioning

Adjustable cushioning is provided as standard and ensures the piston stops smoothly - even at high speeds. (10 mm not adjustable.)

Oil Free Operation

The ORIGA permanent lubricating grease eliminates the need for regular oil mist lubrication and provides long service life.

Cylinders can be used in applications where maximum cleanliness is required. (e.g. electronics pharmaceutical and food processing industries).

Slow Speed Applications

The construction of the ORIGA rodless cylinder allows for a low friction characteristic permitting extremely slow traversing speeds. For speeds below 4 inches/second we recommend that ORIGA "slow speed" lubrication is specified.

Temperature Range/Piston Speed

Standard Buna-N seals are suitable for temperatures from 15° F to +175° F. Viton seals are required for higher temperatures as well as for use when piston speeds exceed 5 ft./sec. Please contact the ORIGA Technical Department if the required operating temperature is above 175° F.

Magnetic Pistons

All Series 2000 cylinders are supplied as standard with magnetic pistons for proximity switch actuation.

Proximity Switches

Magnetically operated Hall Effect switches (IS) or Reed switches (RS) are available to sense piston position at any point over the entire stroke length.

Corrosive Environments

All screws are plated. In extreme applications stainless steel can be supplied. Special aluminum coatings are available for added protection against chemical or caustic wash down of equipment or in environments where corrosive gases are present.

Cylinder Loading

Values are based on shock-free duty and should not be exceeded during piston acceleration.

Note:

Seal life can be significantly influenced by extremes of speed, load and temperature which exceed the approved limits. Contact the ORIGA Technical Department for assistance with special applications.

All specifications are subject to change without notice.

Ordering Procedure

Series 2000

32-2020/20X50-B-M

Cylinder Bore Size: _____
 10, 16, 25, 32, 40 or 50

Configuration: _____
 - = Single Cylinder
 J = Joint Clamp Unit
 C=Clean Room Cylinder

Piston Quantity: _____
 20 = Single Piston
 22 = Double Piston

End Cap Cushion Placement: _____
 20 = Standard Cushion Location (21 for Ø25 & 50mm)
 30 = Cushion at Rear of Cap (31 for Ø25 & 50mm)
 Note: Rear cushions are available on Ø25mm - Ø50mm only.

*Note: When entering total stroke length for 2220/2230 (double piston) cylinders be sure to first add the "CL" distance to the actual, effective stroke length. Enter this total in the cylinder part number. Follow the same procedure for pricing.

Prelube Specification (optional):
 M = Standard
 C = Cleanroom
 F = Food Grade
 S = Slow Speed

Seal Type:
 B = Buna-N
 V = Viton

***Stroke Length:**
 Enter metric strokes followed by "mm" (i.e. 200MM)

Piston Mounting Type:
 20 = Standard Mount 35 = Inverted Floating Mount
 25 = Floating Mount 50 = External Guided Mount
 30 = Inverted Mount(Not available for 10mm)
 PG = Powerguide

For Joint Clamp Cylinders: **See OSP-P Series**
 24 = Platform Mount 34 = Inverted Platform Mount

Series P120

P124-S/20X50-B-M

Cylinder Series P120 _____

Cylinder Bore Size: _____
 4 = 40mm
 6 = 63mm
 8 = 80mm

Piston/Mount Configuration: _____

<u>Short Piston</u>	<u>Long Piston</u>
S/20 = Standard Mount	L/26 = Standard Mount
S/22 = Platform Mount	L/28 = Platform Mount
S/25 = Floating Mount	L/36 = Inverted Mount
S/30 = Inverted Mount	L/38 = Inverted Platform Mount
S/32 = Inverted Platform Mount	
S/35 = Inverted Floating Mount	

Prelube Specification (optional):
 M = Standard
 C = Cleanroom
 F = Food Grade
 S = Slow Speed

Seal Type:
 B = Buna-N
 V = Viton

Stroke Length:
 Enter metric strokes followed by "mm" (i.e. 200MM)

Service Packs

Series 2000
SP32-B-1 X S-M

Service Pack _____
 Bore Size=10, 16, 25, 32, 40, 51
 (Use "50" for 2020 versions)
 B= Buna-N, V= Viton _____
 1 = Single Piston _____
 2 = Double Piston _____
 Enter Stroke Length _____
 Grease Requirements
 M= Standard _____
 S= Slow Speed _____

Series P120
SP124-B-S X S-M

Service Pack _____
 Bore Size: 124=40mm, 126=63mm, 128=80mm _____
 B= Buna-N, V= Viton _____
 S = Short Piston _____
 L = Long Piston _____
 Enter Stroke Length _____
 Grease Requirements
 M= Standard _____
 S= Slow Speed _____

ORIGA International Representation

- (AR) Argentina**
Automación Micromecánica S.A.I.C.
Mariano Moreno 6546 · 1875 Wilde
Pcia. de Buenos Aires
Argentina
Tel. 54-1-207-5808
FAX: 54-1-206-0228
- (A) Austria**
ORIGA
Prinz-Eugen-Strasse
A-1040 Wien (Vienna)
Tel. 43-1-501510
FAX: 43-1-50151300
- (AUS) Australia**
ORIGA
A Division of EHI
605 Burwood Drive
Knoxfield, Victoria 3180
Tel. 61-3801-2223
FAX: 61-3801-8556
- (B) Belgium**
ORIGA B.V.
Verkoop België-Luxemburg
Helleweide 1
B-2930 Brasschaat
Tel. 32-3-6521815
FAX: 32-3-6521847
- (DK) Denmark**
ATLAS COPCO AUTOMATION A/S
Brogrenen 3
DK-2635 ISHOG
Tel. 45-427-38800
FAX: 45-437-38431
- Eastern European Countries**
ORIGA
Prinz-Eugen-Strasse
A-1040 Wien (Vienna)
Tel. 43-1-501510
FAX: 43-1-50151300
- (SF) Finland**
E-LINE ORIGA AB
Kungsgatan 10
Box 67
S-73600 Kungsör
Tel. 46-227-41100
FAX: 46-227-41129
- (F) France**
ORIGA sarl
B.P. 29
F-91121 Palaiseau
Tel. 33-1-6919-2069
FAX: 33-1-6447-1175
- (D) Germany**
ORIGA GmbH Pneumatik
Industriestrasse 8
Postfach 1248
70773 Filderstadt
Sielmingen
Tel. 49-7158-17030
FAX: 49-7158-64870
- (GB) Great Britain**
ORIGA Limited
Tewkesbury Industrial Estate
TEWKESBURY
GB-Gloucestershire GL20 8ND
Tel. 44-684-850000
FAX: 44-684-850555
- (GR) Greece**
ORIGA PNEUMATIK AG
Libern 24
CH-8112 Otelfingen
Tel. 41-1-845-1330
FAX: 41-1-845-1333
- (HK) Hong Kong**
PACK PAL INDUSTRIAL COMPANY
G/FL - 3/FL Tung Shing Mansion
950-954 Canton Road,
Mongkok Kowloon
Tel. 852-782-3222
FAX: 852-385-6198
- (IND) India**
AMBARATI
501 A/B Niranjan
99 Marine Drive
Bombay 400002
Tel. 91-22-2030141
FAX: 91-22-2062937
- (I) Italy**
ORIGA S.r.l.
Via Martiri Della Libertá 4/6
I-20060 Liscate
Milano
Tel. 39-2-95350307
FAX: 39-2-95350513
- (IRL) Ireland**
Irish Pneumatic Services Ltd.
Unit 55E Stillorgan Ind. Park
Blackrock
IRL-CO Dublin
Tel. 353-1-952672
FAX: 353-1-954903
- (IL) Israel**
BACCARA Automation Control
Kvutzat Geva
18915
Tel. 972-6-531606
FAX: 972-6-531445
- (J) Japan**
HOWA Machinery Ltd.
Shinkawa - Cho
Hishikasugai - Gun
Aichi
452 Japan
Tel. 81-52-408-1200
FAX: 81-52-400-7107
- (ROK) Korea**
WU SUNG Pneumatic Company Ltd.
14 L/T. 98 B/L Namdong
Industrial Complex
662-13 Kojan-Dong
Namdong-Ku Incheon
Tel. 82-32-816-2100-7
FAX: 82-32-816-2108-9
- (L) Luxembourg**
ORIGA B.V.
Verkoop België-Luxemburg
Helleweide 1
B-2930 Brasschaat
Tel. 352-3-6521815
FAX: 352-3-6521847
- (MAL) Malaysia**
ALLAN Automation and Pneumatics
Block 5012
Ang Mo Kio Ave 5, 05-01
Techplace II
Singapore 2056
Tel. 65-483-2959
FAX: 65-483-2979
- (MEX) Mexico**
MICRO PNEUMATIC, S.A. DE C.V.
Marle 103-207
Col. Guerrero
06300 México, D.F.
Tel. 52-5-597-3043
FAX: 52-5-597-2980
- (NL) Netherlands**
ORIGA B.V.
P B 3543
NL-5203 DM's
Hertogenbosch
Tel. 31-73-441771
FAX: 31-73-441897
- (NZ) New Zealand**
AUTOMATION PRODUCTS LTD.
P.O. Box 100350
North Shore Mail Centre
NZ-Auckland 1330
Tel. 64-479-3582
FAX: 64-479-3586
- (N) Norway**
E-LINE ORIGA AB
Kungsgatan 10
Box 67
S-73600 Kungsör
Tel. 46-227-41100
FAX: 46-227-41129
- (P) Portugal**
ORIGA Handelsges. AG
Birkenstrasse 49
CH-6343 Rotkreuz
Tel. 042-643858
FAX: 042-643432
- (SGP) Singapore**
ALLAN Automation and Pneumatics
Block 5012
Ang Mo Kio Ave 5, 05-01
Techplace II
Singapore 2056
Tel. 65-483-2959
FAX: 65-483-2979
- (ZA) South Africa**
HOERBIGER S.A. (pty) LTD.
9 Fuchs Street
Alrode 1449
Tel. 27-11-864-1736
FAX: 27-11-864-4733
- (E) Spain**
ORIGA, S.A.
Avda P1 i Margall 27-31
08930 Sant Adria Del Besos
Barcelona
Tel. 34-3-381-2000
FAX: 34-3-381-58081
- (S) Sweden**
E-LINE ORIGA AB
Kungsgatan 10
Box 67
S-73600 Kungsör
Tel. 46-227-41100
FAX: 46-227-41129
- (CH) Switzerland**
ORIGA PNEUMATIK AG
Libern 24
CH-8112 Otelfingen
Tel. 41-1-845-1330
FAX: 41-1-845-1333
- (RC) Taiwan**
DA ING ENTERPRISE CO. LTD.
No. 43, Lane 244
Tun Hwa N. Rd.
RC- Taipei/Taiwan
Republic of China
Tel. 886-2-7131292
FAX: 886-2-7172640
- (T) Thailand**
ALLAN Automation and Pneumatics
Block 5012
Ang Mo Kio Ave 5, 05-01
Techplace II
Singapore 2056
Tel. 65-483-2959
FAX: 65-483-2979
- (TR) Turkey**
ORIGA GmbH Pneumatik
Industriestrasse 8
Postfach 1248
D/W-7024 Filderstadt 1
Tel. 49-7158/17030
FAX: 49-7158/64870
- (USA) United States of America**
HOERBIGER-ORIGA CORPORATION
100 West Lake Drive
Glendale Heights, Illinois 60139
USA
Tel. 630-871-8300
FAX: 630-871-1515

NOTE: All listings include country codes and city codes.

Installation

The versatility of the Origa rodless cylinder is demonstrated in a wide range of applications.

Proven technology, used worldwide in all areas where lifting and transfer operations are required.

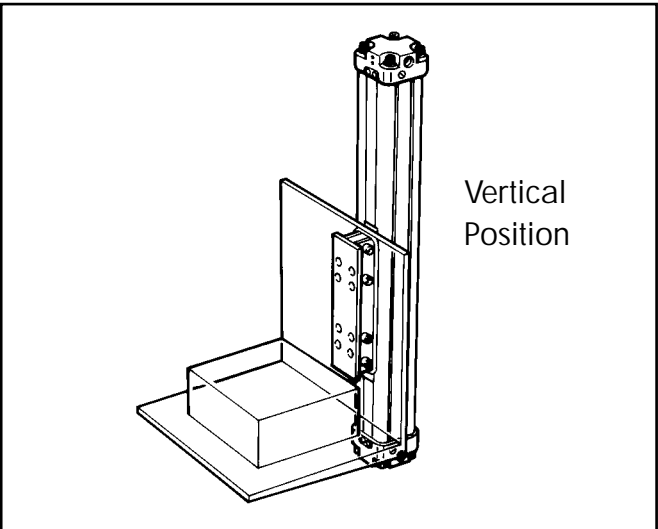
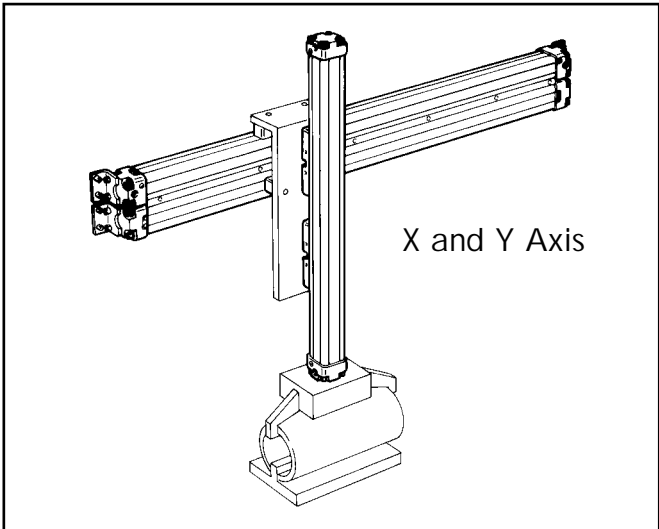
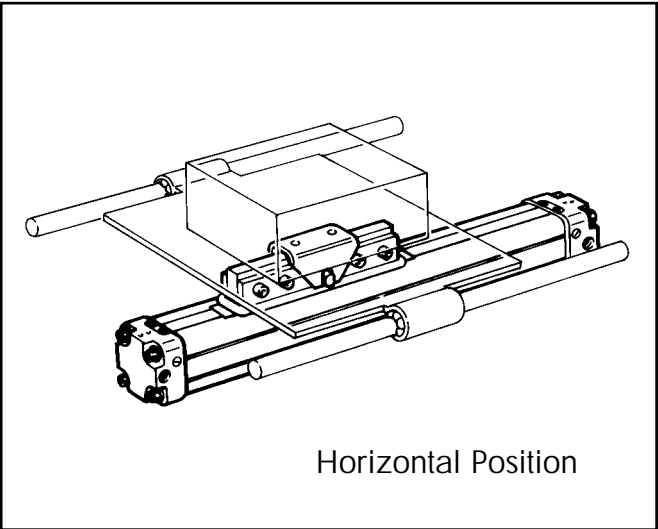
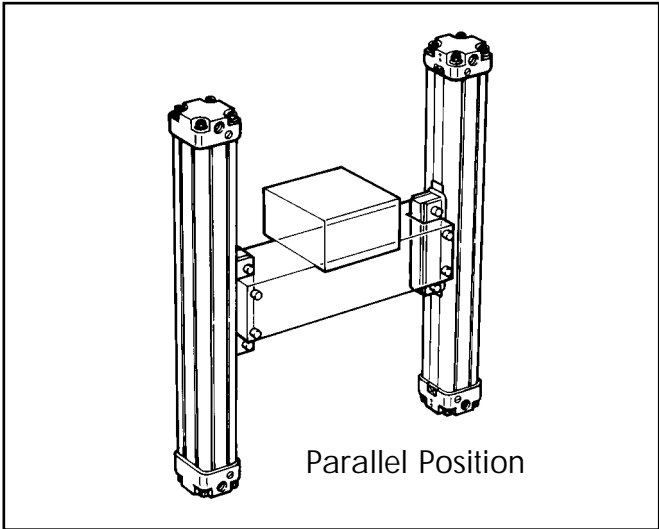

Valving

The unique, mechanical design of the Origa rodless cylinder allows for a variety of valves and pneumatic circuit configurations. The diagrams shown below illustrate circuit examples used to obtain a particular output function.

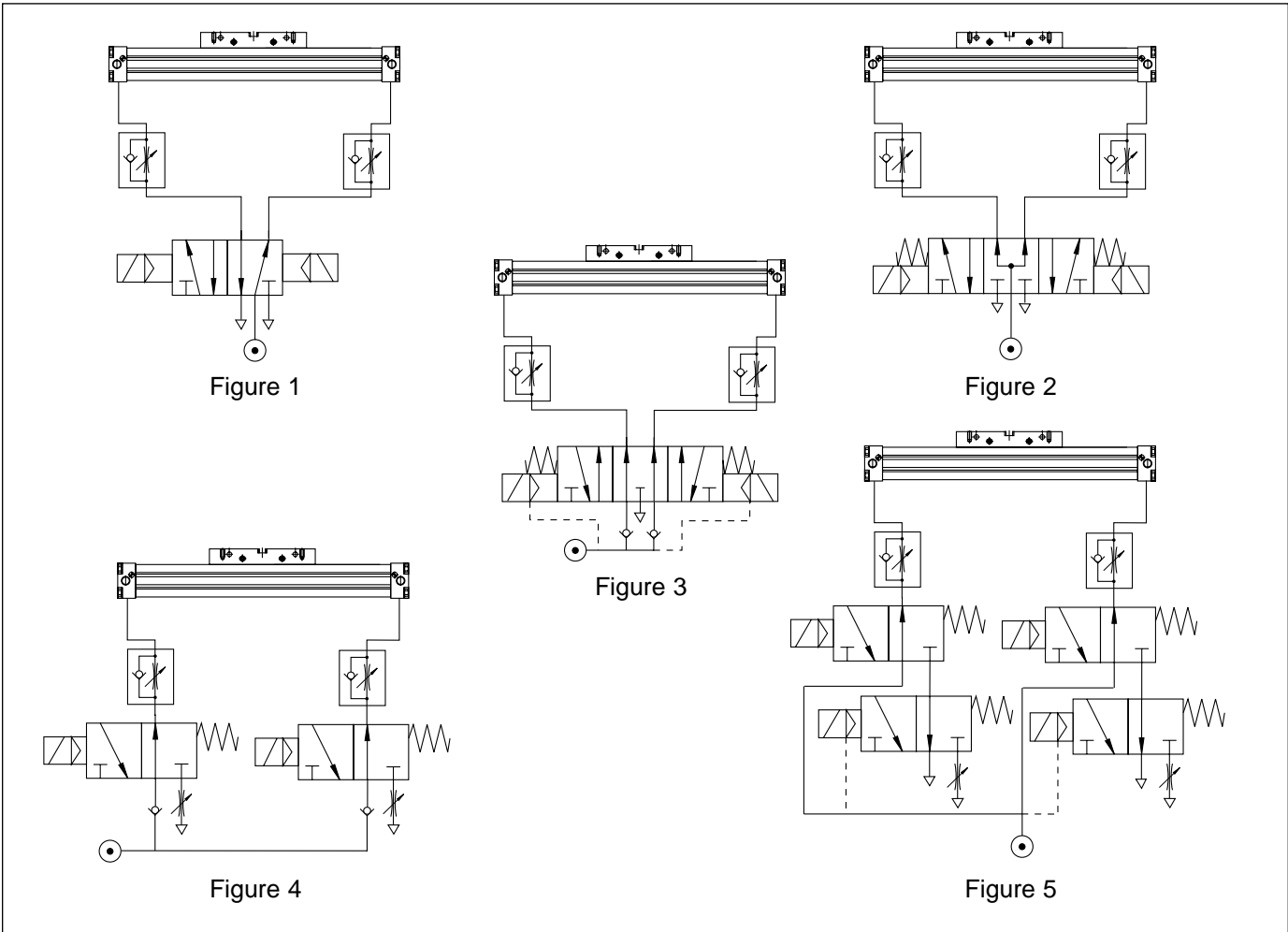

Figure 1. Speed controlled forward and backward motion.

Figure 2. For positioning when no external forces are present.

Figure 3. For accurate positioning. Check valves prevent external forces from moving the piston. Recommended for short stroke cylinders.

Figure 4. For accurate positioning. The valves should be located directly at the connection ports of the cylinder. Recommended for long stroke cylinders.

Figure 5. Recommended for accurate positioning at high velocities. Also when the load is too large to be handled by the standard cushions. An additional 3/2 way valve, including throttle control, connected to the exhaust port of the ordinary valve is used. This makes it possible to increase the throttling of the airflow before reaching positioning points or end positions. This allows a higher positioning repeatability and improved cushioning.

Applications

For more than 20 years
Origa cylinders have provided solutions
to linear motion problems
in all types of industry.

Offering simple designs,
easy installation, clean operation
and maintenance free duty,
Origa cylinders are suitable for
a diversity of applications and
environments. A variety of examples
are shown on the following pages.

For more information or
assistance with your linear
motion tasks. Please call an
authorized distributor or
Origa direct.

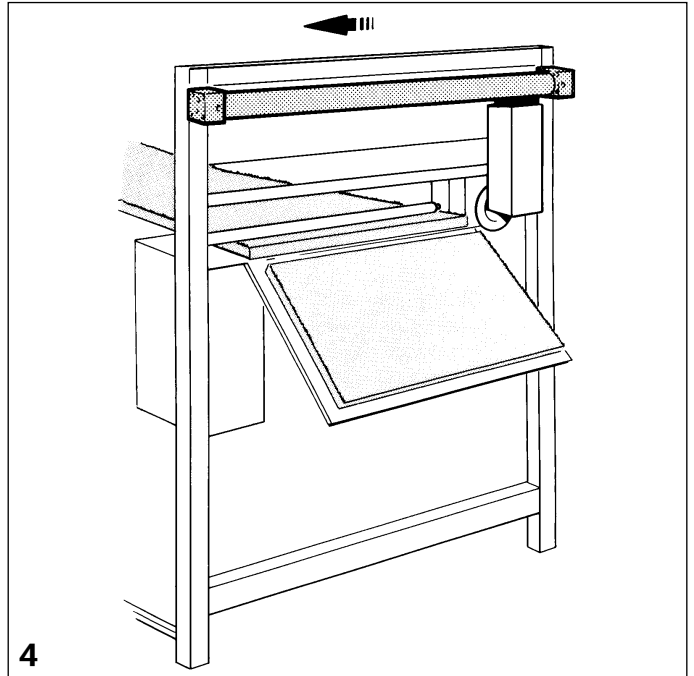
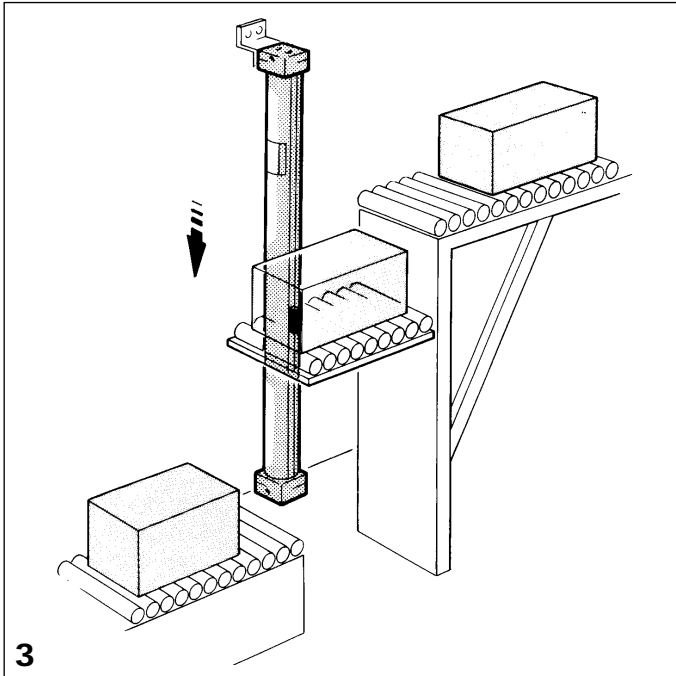
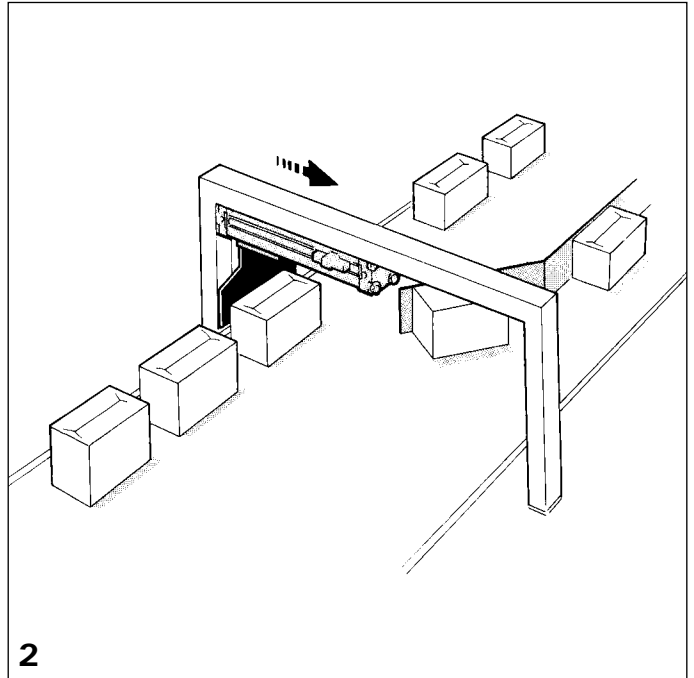
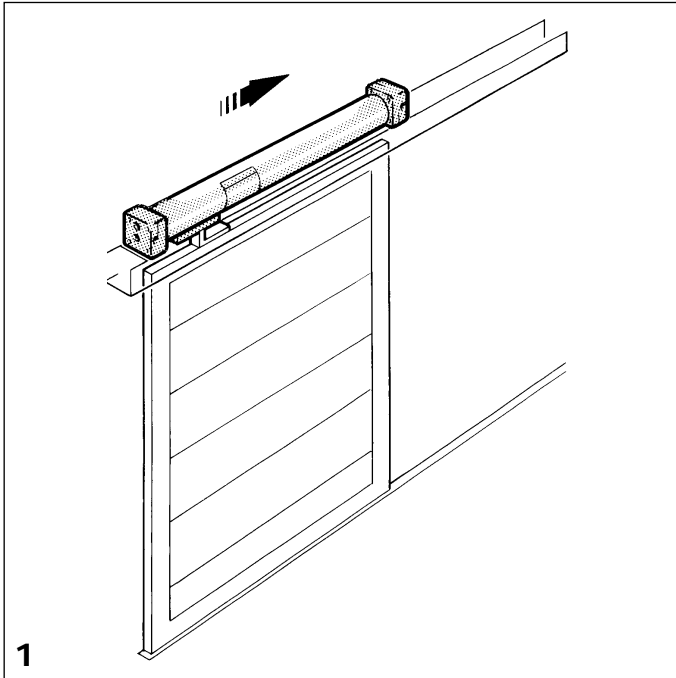

Application Descriptions

- No.1 Door Traverse -
- No.2 Conveyor Reject Systems -
- No.3 Conveyor Elevator -
- No.4 Flying Cutter -

Benefits

- Long strokes, equal forces in both directions, smooth consistent movement, space savings and ease of installation.
- Self-guiding, high-speed operation and compact design.
- Cantilever loading, self-guiding, long strokes, space saving and forms a part of the structure.
- High speeds, self-guiding, space saving, forms main structure of assembly. Made to any stroke length.

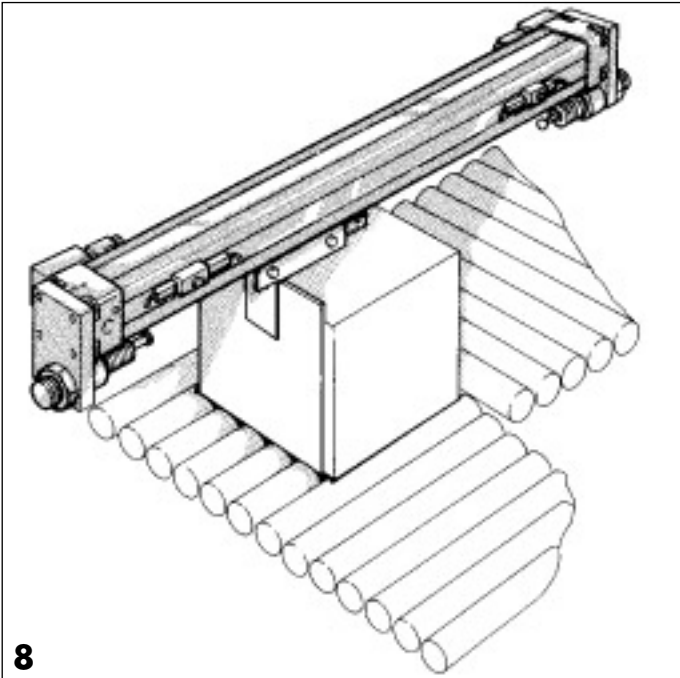
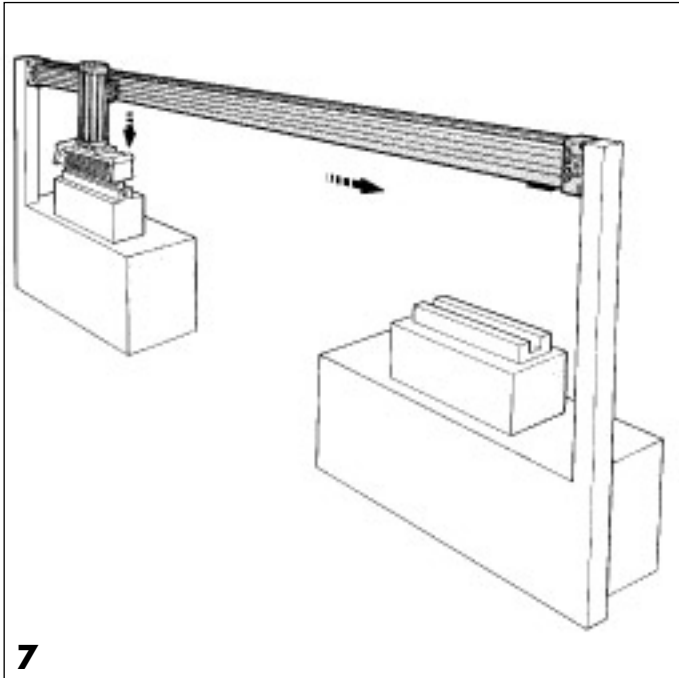
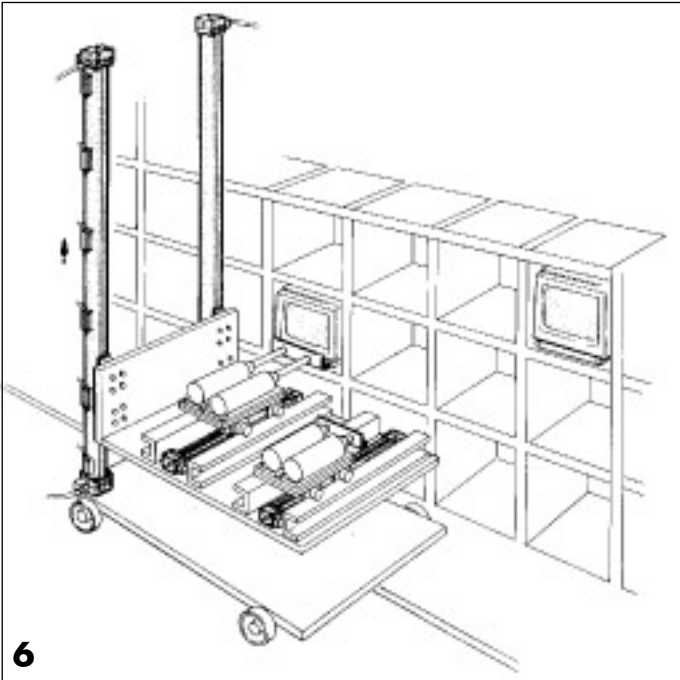
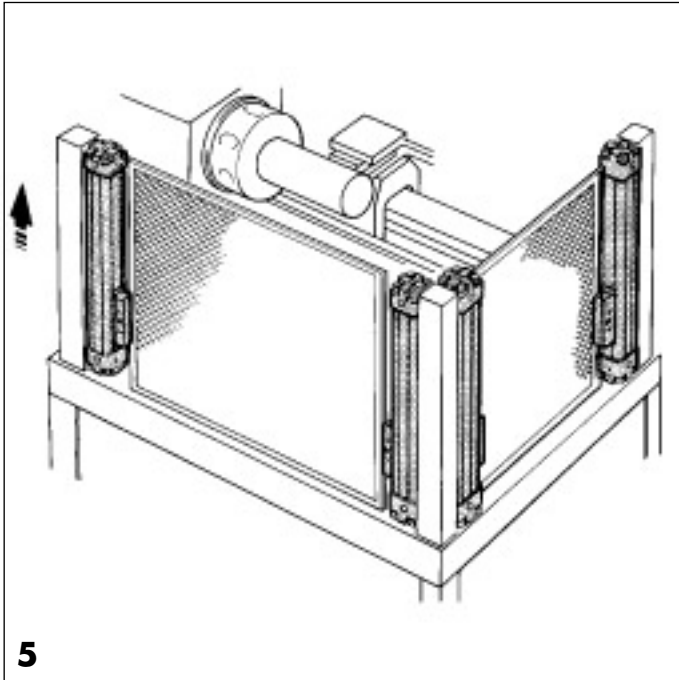

Application Descriptions

- No.5 Machine Guards -**
- No.6 Auto-Handling Systems -**
- No.7 X-Y Axis, Pick and Place -**
- No.8 Conveyor Transfer -**

Benefits

- Parallel operation, self-guiding, compact design.
- Parallel operation, self-guiding, cantilever loading, space savings and controllability.
- Self-guiding, compact design, no additional structural supports.
- Self-guiding, compact design, equal force in both directions, no additional support or guidance.

9

10

11

12

Application Descriptions

No.9 Process Dipping -

No.10 Belt Tracking -

No.11 Steel Mill - Roll Wiper -

No.12 Autohandling Systems -

Benefits

- Cantilever loading, internally guided, high load capability, slow speed controlability, design simplicity.
- Self-guiding, intermediate positioning capability, maintenance-free operation.
- Self-guiding, suitable for high-cycle duty, reliable in arduous environments.
- Multi-axis capability, intermediate positioning, no auxiliary guides or structural support, simple design.

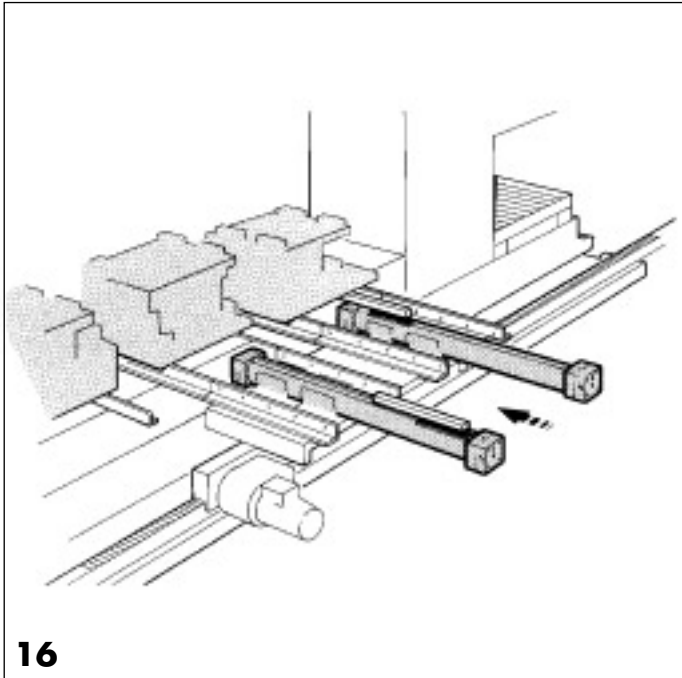
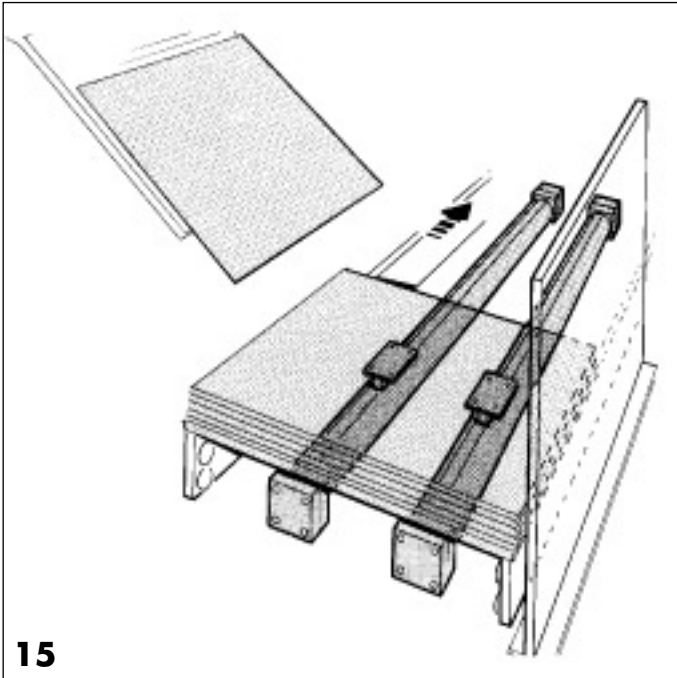
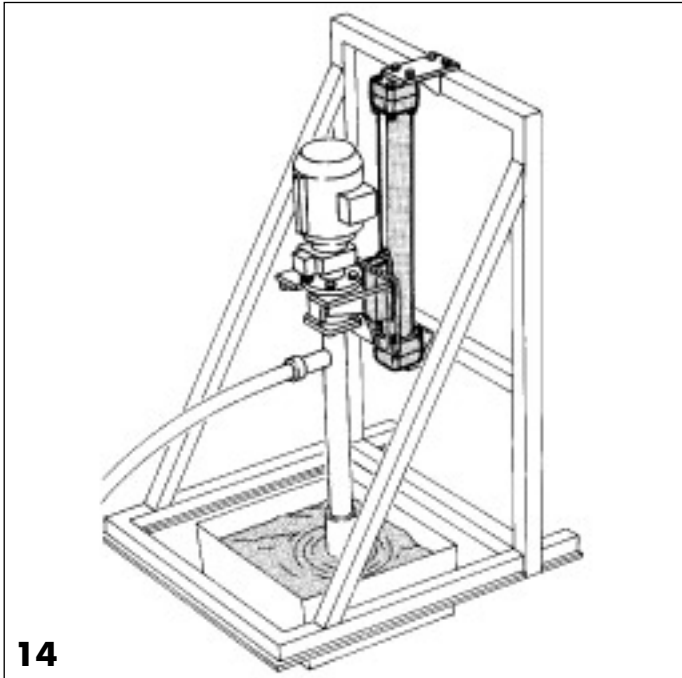
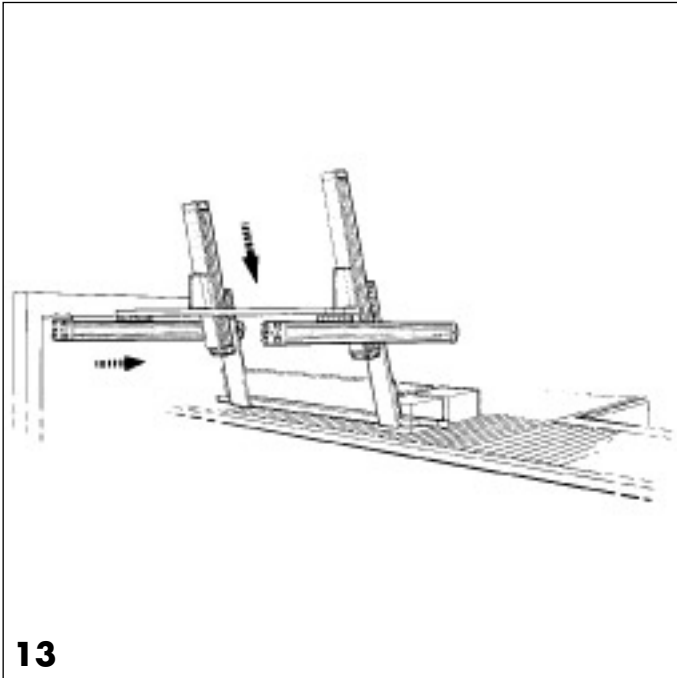

Application Descriptions

- No.9 Palletizing -
- No.10 Pump Elevator -
- No.11 Pallet Handling -
- No.12 Tool Die Handling -

Benefits

- Parallel operation, self-guiding, accepts high cantilever loads, inherently rigid construction.
- Accepts high cantilever loads, simple construction, minimal engineering.
- Parallel operation, controlled motion of high loads, reliability in arduous environments.
- Controlled movement of heavy loads, equal force in both directions, simple and space saving design.

Six Unique Advantages

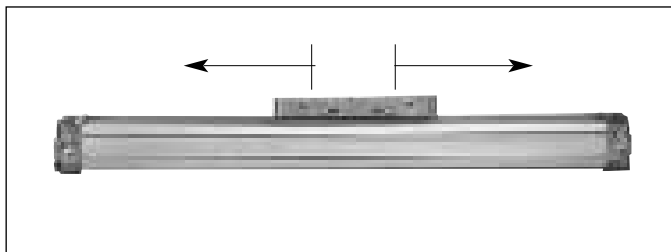

Equal Force and Speed

Equal piston area on each side of the piston allows for equal force and speed in both directions of travel. Additionally, the ability to “pneumatically lock” the piston at various points along the stroke is possible through the use of special valve configurations. (See page 2.0/2)

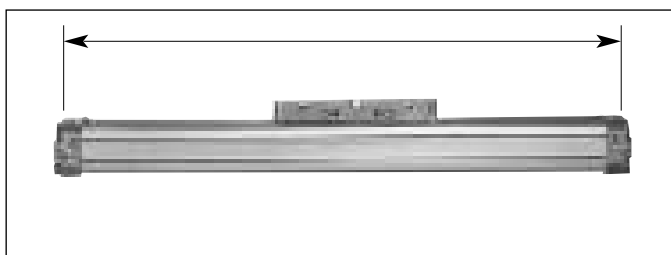

Any Length of Stroke

Infinitely variable strokes are available up to 480 inches and each cylinder is custom manufactured to customer requirements without incurring extended delivery times.

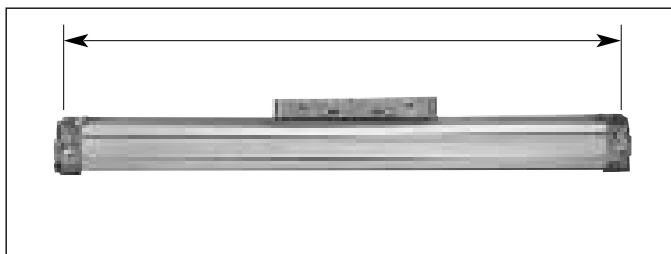

Space Saving

The lack of a piston rod allows for nearly half the space requirement of a “rod type” pneumatic cylinder. The result is a simpler, less costly installation reducing the amount of hardware and design time.

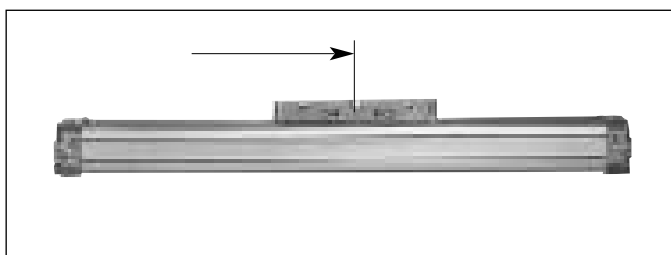

Accepts Cantilever Loads

The unique piston design and barrel rigidity allows the Origa cylinder to accept high direct and bending moment loads without the need for additional support hardware.

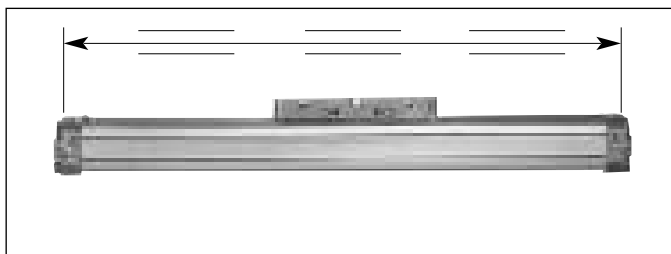

Self Guiding

The internal self-supporting characteristics of the Origa rodless cylinder provides guidance of the piston throughout the stroke. High priced guidance mechanisms (roundway bearings, precision slideways, etc.) are not required.

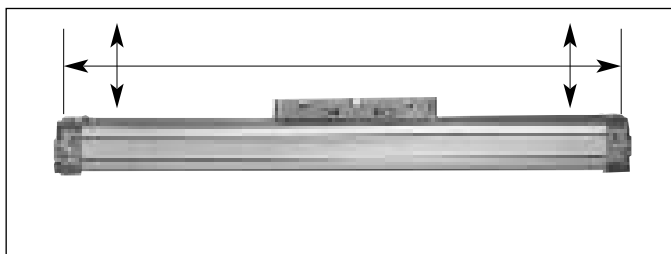

Inherent Rigidity

Integral strength and rigidity of the complete cylinder assembly will accommodate the heaviest of loads enabling the cylinder to form part of a structure or framework. This eliminates the need for expensive and bulky I-beams, channels and fabrications.

The Product Range

Section 3.1

Series 2000 - Basic Cylinder

Bore sizes (mm): 10, 16, 25, 32, 40, 50

The basic cylinder series satisfies the support and guidance requirements of a great diversity of applications. Various mounting and control options are available for specific application needs.

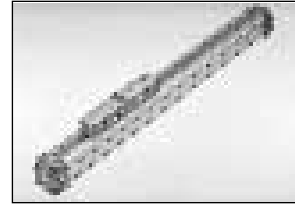

Section 3.2

Series 2000 - Joint Clamp

Bore sizes (mm): 25, 32, 40, 50

Two cylinders mounted in a tandem configuration for increased load and force requirements. The arrangement enhances lateral support and bending moment capabilities.



Section 3.3

Series 2000 - NR50

See OSP-P Series

Bore sizes (mm): 16, 25, 32, 40, 50

An attached slide bearing option for increased load and bending moment capability, enabling greater design flexibility. Four full-face bearings running on a "V" guide provide for greater lateral support and increased system rigidity.



Section 3.4

Series 2000 - Powerguide™

See OSP-P Series

Bore sizes (mm): 25, 32, 50

Designed for the most demanding applications, Powerguide offers an integral "V" guide with precision roller bearings. Hardened steel bearings provide long life and excellent resistance to wear, even in the most arduous conditions. The carriage is adjustable to eliminate free-play and is supplied in a factory pre-set condition.



Section 3.5

Series P120 - Basic Cylinder

Bore sizes (mm): 40, 63, 80

For high force and load requirements, the P120 series provides optimal strength and a unique package of options.



Technical Summary

2020/20

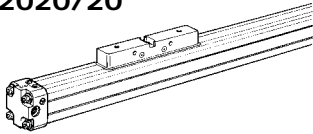

2020/25

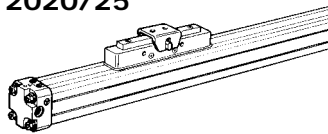

2020/30

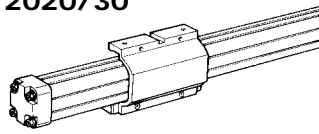

2020/35

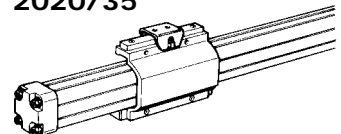

2220/20

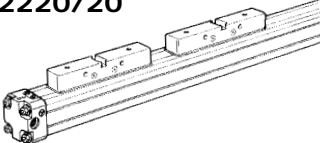

2220/30

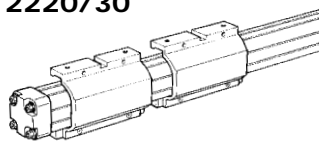

J2020/24

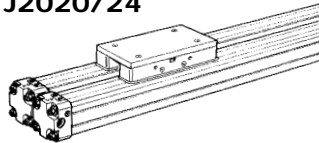

J2020/34

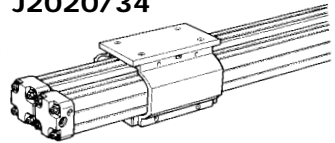

Series	Cyl. Ø (mm)	Theoretical Force at 87 PSI (lbs. force)	Cushion Length (in.)	Max. Allowed Bending Moment Ma (in./lbs.)	Max. Allowed Bending Moment Ms (in./lbs.)	Max. Allowed Bending Moment Mv (in./lbs.)	Max. Allowed Load L (lbs.)
Series 2000 Single Piston	10	11	0.10	9	2	3	5
	16	27	0.59	35	3	5	30
	25	66	0.55	132	9	27	65
	32	108	1.10	318	36	120	115
	40	169	1.42	575	53	156	195
50	265	1.50	1017	98	312	270	
Series 2000 Double Piston	10	11	0.10	21	4	5	10
	16	27	0.59	81	6	9	60
	25	66	0.55	336	18	45	130
	32	108	1.10	720	72	600	230
	40	169	1.42	1320	106	792	390
50	265	1.50	2304	196	1464	540	
Joint Clamp Single Piston	25	132	0.55	264	115	54	130
	32	216	1.10	636	248	240	230
	40	338	1.42	1150	444	312	390
	50	530	1.50	2034	859	624	540
Joint Clamp Double Piston	25	132	0.55	672	230	90	260
	32	216	1.10	1440	496	1200	460
	40	338	1.42	2640	888	1584	780
	50	530	1.50	4608	1718	2928	1080
NR50 External Guide	16	27	0.59	100	54	100	81
	25	66	0.55	252	216	252	325
	32	108	1.10	576	504	576	500
	40	169	1.42	792	648	792	575
	50	265	1.50	1584	1080	1584	750
Powerguide External Slideway	25	66	0.55	451	98	451	263
	32	108	1.42	1200	451	1200	526
	50	265	1.50	3850	1566	3850	900
Series P120 Short Piston	40	169	1.26	528	36	72	170
	63	420	1.57	1776	72	216	370
	80	677	1.73	3192	144	420	590
Series P120 Long Piston	40	169	1.26	1200	72	216	170
	63	420	1.57	3984	144	660	370
	80	677	1.73	6372	288	1236	590

Technical Summary

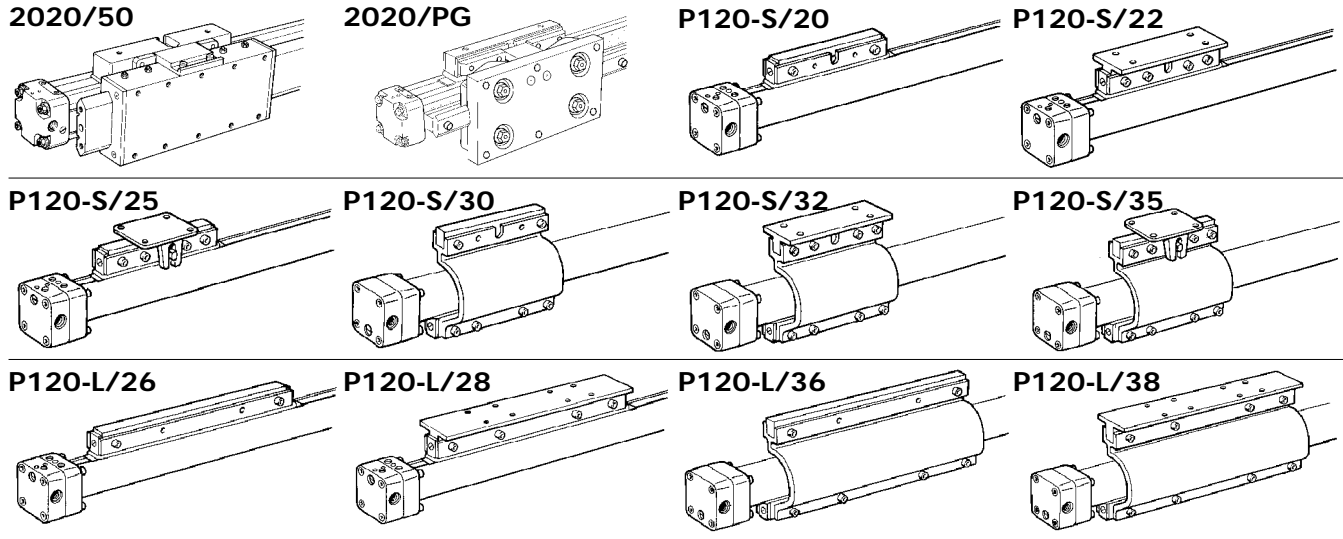

Cushion Diagram Series 2000

Bore	Color Key
10mm	█
16mm	█
25mm	█
32mm	█
40mm	█
50mm	█

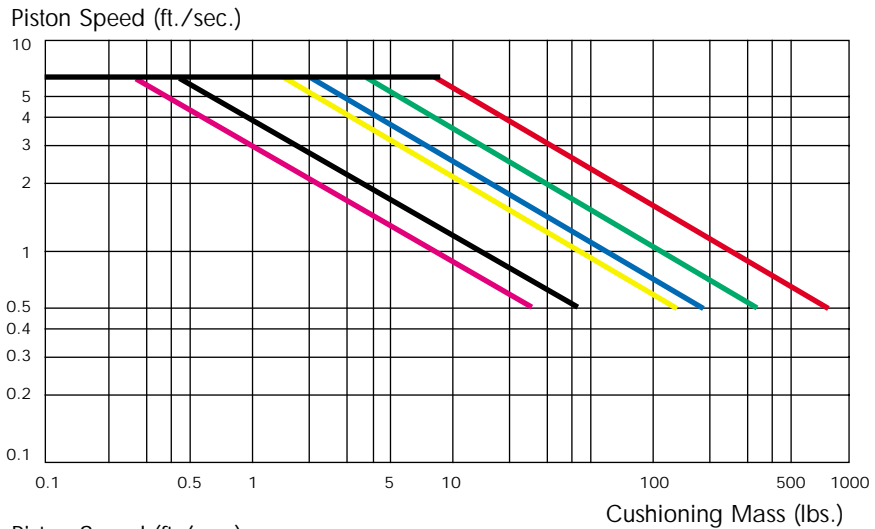

Cushion Diagram Series P120

Bore	Color Key
40mm	█
63mm	█
80mm	█

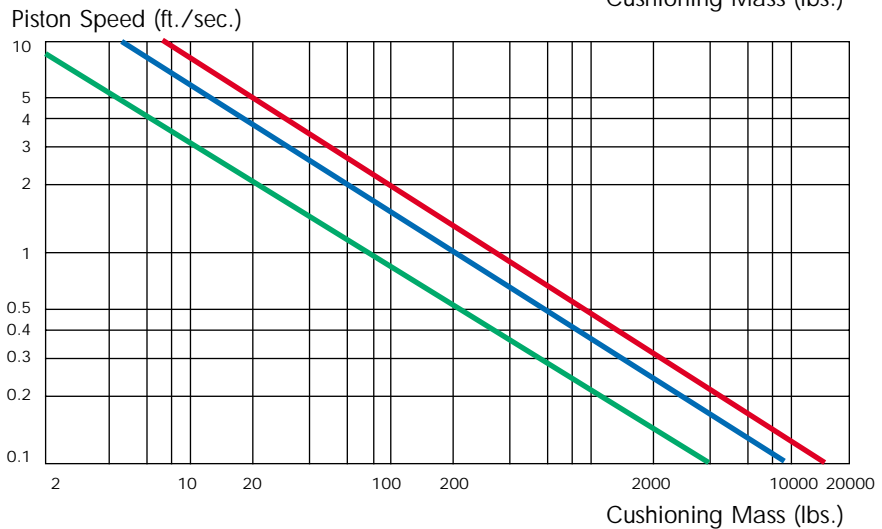

Series 2000 Basic Cylinder

Bore sizes: 10mm, 16mm, 25mm, 32mm, 40mm and 50mm
Stroke lengths available up to 480"



Technical Data

Loads, forces, moments

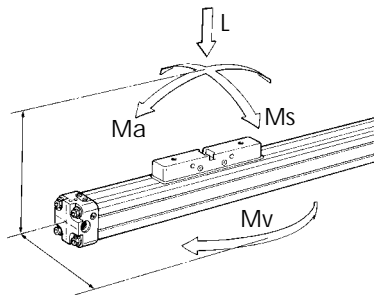

Single Piston Values

Cyl. Ø (mm)	Theoretical Force at 87 PSI (lbs. force)	Cushion Length (in.)	Max. Allowed Bending Moment Ma (in./lbs.)	Max. Allowed Bending Moment Ms (in./lbs.)	Max. Allowed Bending Moment Mv (in./lbs.)	Max. Allowed Load L (lbs.)
10	11	0.10	9	2	3	5
16	27	0.59	35	3	5	30
25	66	0.55	132	9	27	65
32	108	1.10	318	36	120	115
40	169	1.42	575	53	156	195
50	265	1.50	1017	98	312	270

Double Piston Values

Cyl. Ø (mm)	Theoretical Force at 87 PSI (lbs.)	Cushion Length (in.)	Max. Allowed Bending Moment Ma (in./lbs.)	Max. Allowed Bending Moment Ms (in./lbs.)	Max. Allowed Bending Moment Mv (in./lbs.)	Max. Allowed Load L (lbs.)
10	11	0.10	21	4	5	10
16	27	0.59	81	6	9	60
25	66	0.55	336	18	45	130
32	108	1.10	720	72	600	230
40	169	1.42	1320	106	792	390
50	265	1.50	2304	196	1464	540

Cushioning Diagram

Bore	Color Key
10mm	█
16mm	█
25mm	█
32mm	█
40mm	█
50mm	█

Piston Speed (ft./sec.)

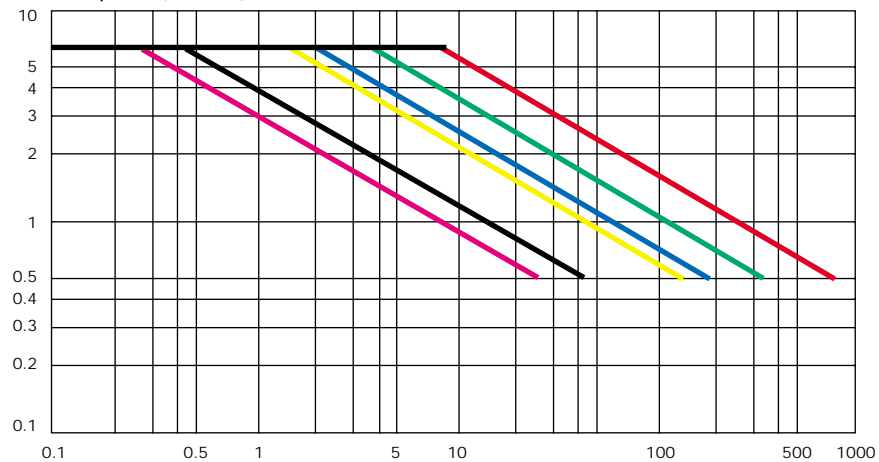

Cushioning Mass (lbs.)

Piston Mountings

Ø 10mm and 16mm

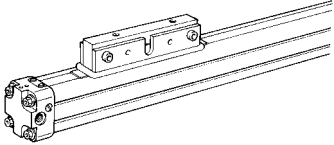
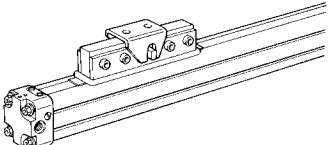
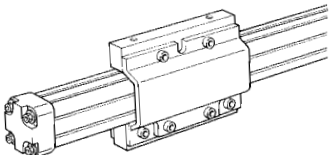
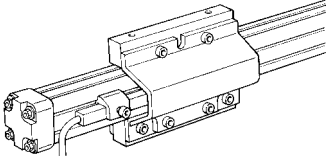
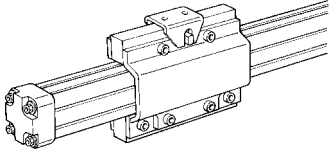
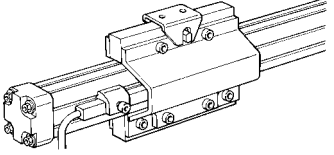
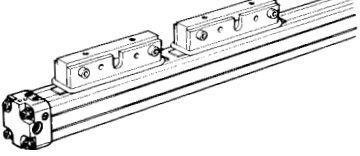
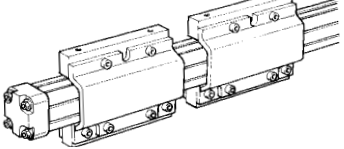
Designation	Pictorial Representation	Description	Cyl. Ø	Weight 0" stroke (lbs.)	Weight per inch (lbs.)
Type 2020/20		Piston Mounting NR20 Standard mounting. Mounted during cylinder assembly.	10	0.20	0.03
			16	0.51	0.05
Type 2020/25		Piston Mounting NR25 Allows for a floating connection between the cylinder and an externally guided device.	10	0.22	0.03
			16	0.55	0.05
Type 2020/30		Piston Mounting NR30 Transfers power to the back of the cylinder. Protects the band surface from foreign particles.	10	--	0.03
			16	0.73	0.05
Type 2020/34		Piston Mounting NR34 Same features as the NR30. For use with cylinders which have sensors on both sides of the barrel.	10	--	0.03
			16	0.77	0.05
Type 2020/35		Piston Mounting NR35 Combines the features of the NR25 mounting and the NR30 mounting.	10	--	0.03
			16	0.77	0.05
Type 2020/37		Piston Mounting NR37 Same features as the NR35. For use with cylinders which have sensors on both sides of the barrel.	10	--	0.03
			16	0.80	0.05
Type 2220/20		Double Piston Mounting NR20 Two pistons in a single barrel using the standard NR20 mounting.	10	0.27	0.03
			16	0.67	0.05
Type 2220/30		Double Piston Mounting NR30 Two pistons in a single barrel using the NR30 mounting.	10	--	0.03
			16	1.11	0.05

Piston Mountings

Ø 25mm, 32mm, 40mm and 50mm

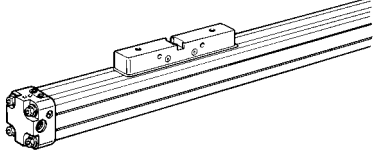
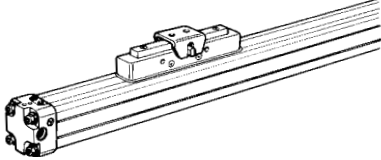
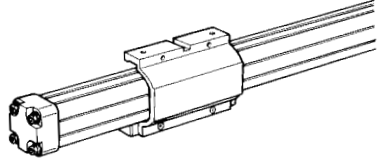
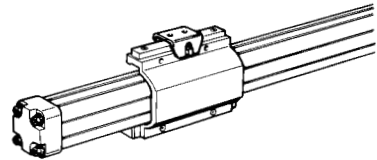
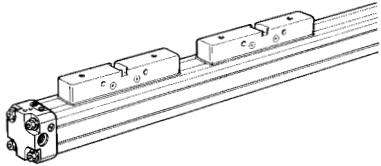
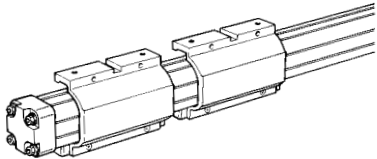
Designation	Pictorial Representation	Description	Cyl. Ø	Weight 0" stroke (lbs.)	Weight per inch (lbs.)
Type 2020/20		Piston Mounting NR20 Standard mounting. Mounted during cylinder assembly.	25	1.32	0.11
			32	3.19	0.20
			40	5.17	0.29
			50	7.70	0.43
Type 2020/25		Piston Mounting NR25 Allows for a floating connection between the cylinder and an externally guided device.	25	1.54	0.11
			32	3.85	0.20
			40	5.83	0.29
			50	9.46	0.43
Type 2020/30		Piston Mounting NR30 Transfers power to the back of the cylinder. Protects the band surface from foreign particles.	25	1.87	0.11
			32	4.40	0.20
			40	6.60	0.29
			50	10.45	0.43
Type 2020/35		Piston Mounting NR35 Combines the features of the NR25 mounting and the NR30 mounting.	25	2.09	0.11
			32	5.06	0.20
			40	7.26	0.29
			50	12.22	0.43
Type 2220/20		Double Piston Mounting NR20 Two pistons in a single barrel using the standard NR20 mounting.	25	2.05	0.11
			32	5.15	0.20
			40	9.10	0.29
			50	13.2	0.43
Type 2220/30		Double Piston Mounting NR30 Two pistons in a single barrel using the NR30 mounting.	25	2.60	0.11
			32	6.37	0.20
			40	10.31	0.29
			50	15.95	0.43

Overall Dimensions

Ø 10mm and 16mm

Basic Dimensions (Single Piston)

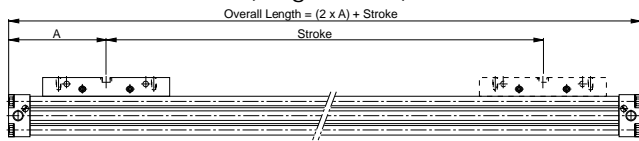

Basic Dimensions (Double Piston)

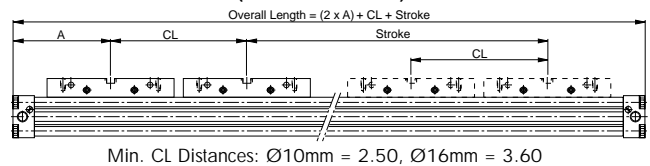

End Cap Dimensions Ø 10mm

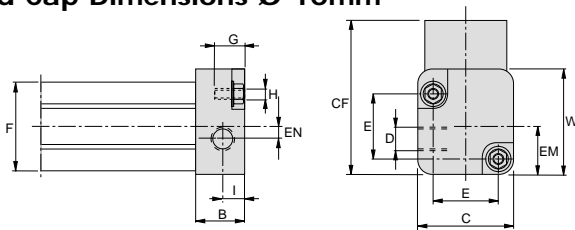

End Cap Dimensions Ø 16mm

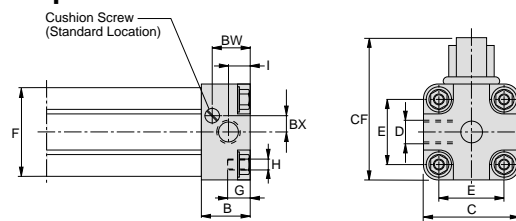

Piston Mounting NR20

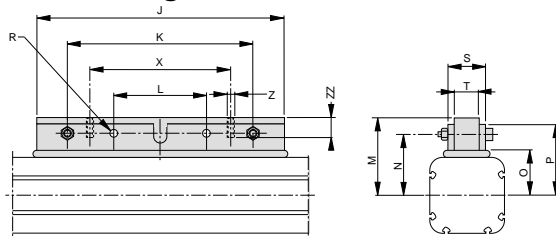

Piston Mounting NR25

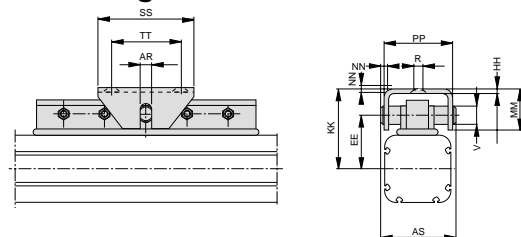

Piston Mounting NR30

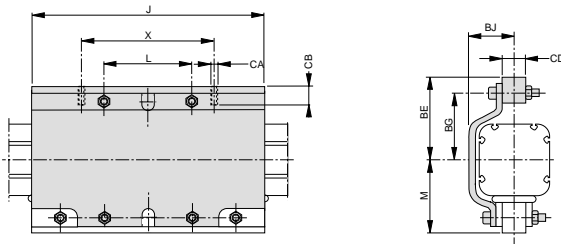

Piston Mounting NR34

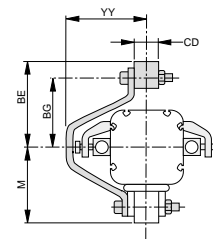

Piston Mounting NR35

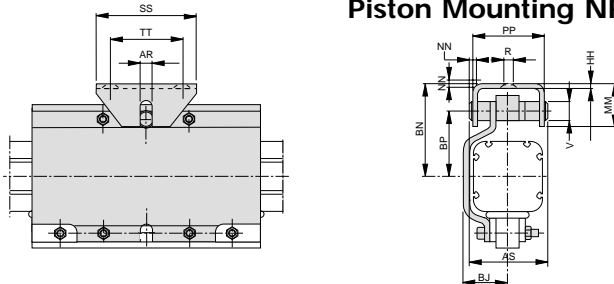

Piston Mounting NR37

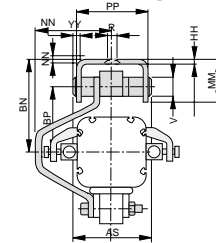

Cyl. Ø	A	B	C	D	E	F	G	H	I	J	K	L	M	N	O	P	R	S	T	V	W	X	Z	AR
10	1.75	.47	.75	M5	.47	.67	.20	M3	.24	2.36	---	.87	.89	.69	.41	.85	.13	.63	.39	.14	.85	1.22	M3	.08
16	2.56	.59	1.06	M5	.71	.94	.20	M3	.22	2.99	2.52	1.26	1.18	.94	.63	1.14	.18	.71	.39	.20	---	1.89	M4	.12
Cyl. Ø	AS	BE	BG	BJ	BN	BP	BW	BX	CA	CB	CD	CF	EM	EN	HH	KK	LL	MM	NN	PP	SS	TT	YY	ZZ
10	1.06	---	---	---	---	---	---	---	---	---	---	1.26	.37	.08	.08	1.02	.73	.45	.04	.94	.79	.39	---	.24
16	1.10	1.14	.91	.71	1.30	.91	.47	.16	M4	.47	.63	1.71	---	---	.08	1.34	.96	.51	.06	.98	.79	.39	1.34	.31

Overall Dimensions

Ø 25mm, 32mm, 40mm and 50mm

Basic Dimensions (Single Piston)

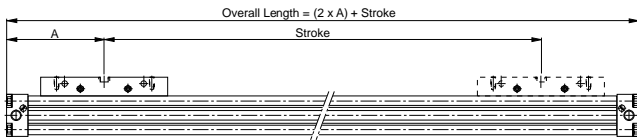

Basic Dimensions (Double Piston)

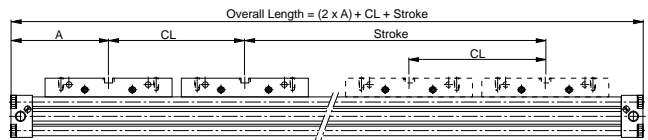

End Cap Dimensions

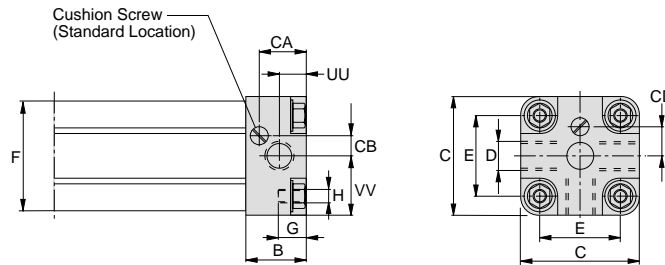

Piston Mounting NR20

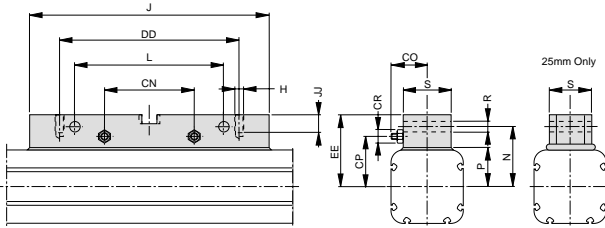

Piston Mounting NR25

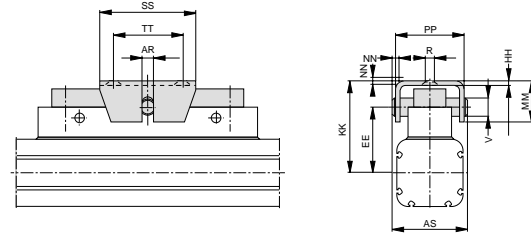

Piston Mounting NR30

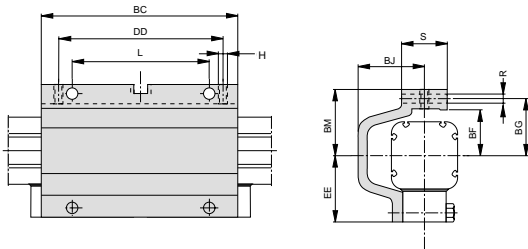

Piston Mounting NR35

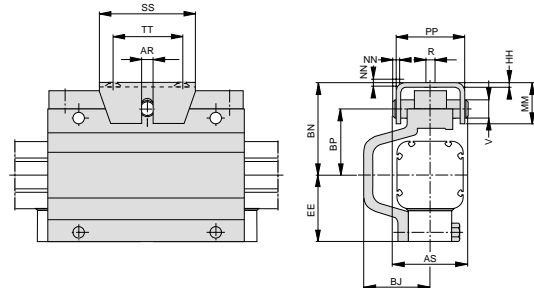

Cyl. Ø	A	B	C	D	E	F	G	H	J	L	N	P	R	S	U	V	DD	EE	HH	JJ
25	3.94	.91	1.57	1/8 NPT	1.06	1.42	.35	10-32	4.72	1.97	1.30	.75	.22	.91	.22	.31	3.15	1.50	.12	.35
32	4.92	1.06	2.09	1/4 NPT	1.42	1.93	.47	1/4-20	6.30	3.94	1.57	1.10	.26	1.26	.26	.47	4.72	1.89	.16	.47
40	5.91	1.06	2.48	1/4 NPT	1.81	2.32	.47	1/4-20	6.30	3.94	1.81	1.34	.26	1.26	.26	.47	4.72	2.13	.16	.47
50	6.70	1.26	3.07	3/8 NPT	2.13	2.83	.47	5/16-18	7.87	5.51	2.17	1.57	.35	1.34	.35	.63	6.30	2.56	.20	.63

Cyl. Ø	KK	LL	MM	NN	PP	SS	TT	UU	VV	AR	AS	BC	BF	BG	BJ	BM	BN	BP	CA	CB	CD	CL (min.)
25	2.05	1.50	.79	±.10	1.46	1.26	.63	.33	.81	.20	1.65	4.25	1.10	1.30	1.50	1.50	2.05	1.50	.71	.26	.35	5.12
32	2.60	1.89	1.18	±.16	1.97	2.76	1.97	.41	1.04	.31	2.28	5.67	1.26	1.57	1.89	1.89	2.60	1.89	.83	.35	.51	6.90
40	2.83	2.13	1.18	±.16	1.97	2.76	1.97	.41	1.24	.31	2.28	5.67	1.50	1.81	2.13	2.13	2.83	2.13	.71	.51	.65	8.75
50	3.54	2.56	1.77	±.24	2.28	3.94	3.15	.49	1.54	.39	2.83	7.24	1.77	2.17	2.56	2.56	3.54	2.56	.83	.59	.73	10.00

Cylinder Mountings

Designation	Pictorial Representation	Description	Cyl. Ø	Part Number	Weight (lbs.)
Type NR4		End Cap Mounting	10	2172-0001	0.02
			16	2172-0101	0.02
			25	2172-0201	0.07
			32	2172-0351	0.11
			40	2172-0451	0.13
			50	2172-0551	0.26
Type NR7 (Ø 10mm & 16mm only)		Center Support	10	2176-0001	0.01
			16	2176-0101	0.01
Type NR7 (Ø 25mm - 50mm only)		Center Support	25	2176-0202	0.07
			32	2176-0351	0.13
			40	2176-0451	0.15
			50	2176-0551	0.44
Type NR8 (Ø 25mm - 50mm only)		Center Support	25	2175-0201	0.04
			32	2175-0351	0.07
			40	2175-0451	0.07
			50	2175-0551	0.26

Center Support Placement

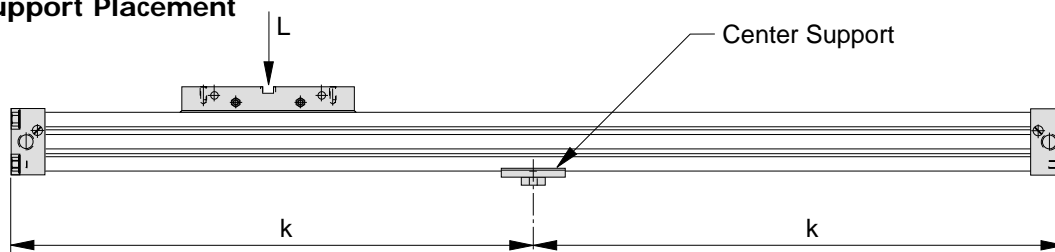

Bore	Color Key
10mm	█
16mm	█
25mm	█
32mm	█
40mm	█
50mm	█

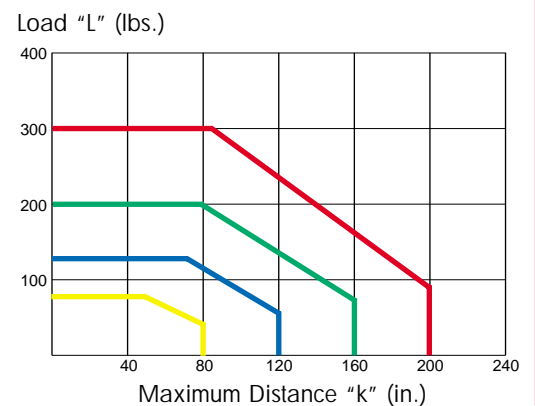
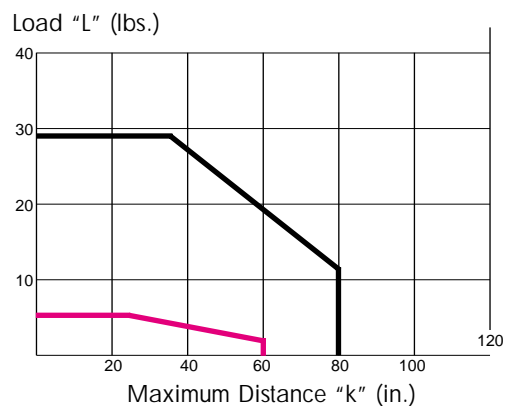

Dimensions - Cylinder Mountings

End Cap Mounting NR4

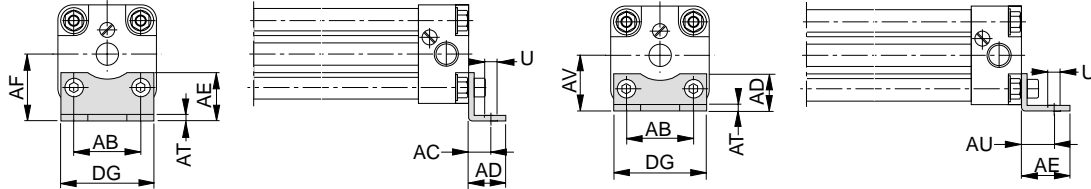

NR4 Mounting Bracket - Mtg. Style "A"

NR4 Mounting Bracket - Mtg. Style "B"

Center Support Mounting NR7 (Ø10mm - 16mm)

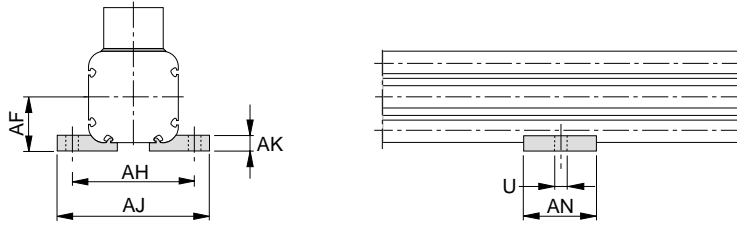

Center Support Mounting NR7 (Ø25mm - 50mm)

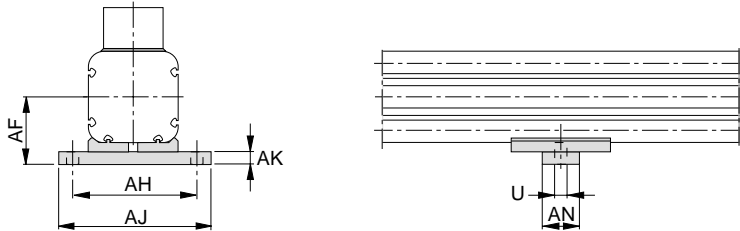

Center Support Mounting NR8

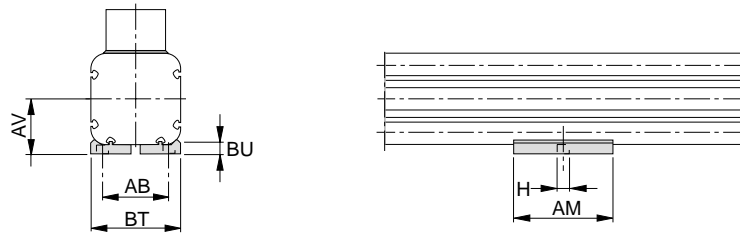

Cyl. Ø	U	AB	AC	AD	AE	AF	AH	AJ	AK	AM	AN	AT	AU	AV	BT	BU	DG	H
10	.14	.47	.39	.55	.80	.43	1.00	1.31	.14	-	.47	.06	-	-	-	-	.72	-
16	.14	.71	.39	.55	.49	.59	1.26	1.57	.18	-	.47	.06	-	-	-	-	1.02	-
25	.22	1.06	.41	.71	.87	1.10	1.89	2.36	.16	1.26	.79	.08	.57	.94	1.42	.21	1.54	10-32
32	.26	1.42	.47	.79	1.02	1.42	2.60	3.23	.24	1.57	.79	.12	.71	1.18	1.89	.22	1.97	1/4-20
40	.26	1.81	.47	.79	1.02	1.61	2.99	3.62	.24	1.57	.79	.12	.71	1.38	2.28	.22	2.36	1/4-20
50	.35	2.13	.71	1.10	1.34	2.01	3.70	4.49	.24	2.48	1.57	.16	.94	1.77	2.83	.33	2.91	5/16-18

Series 2000 Joint Clamp

Bore sizes: 25mm, 32mm, 40mm and 50mm
Stroke lengths available up to 480"



Technical Data

Loads, forces, moments

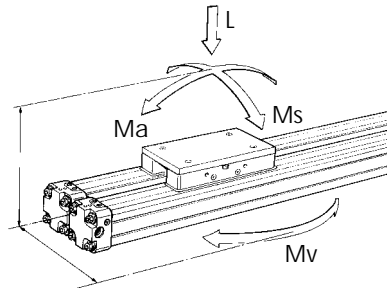

Single Piston Values

Cyl. Ø (mm)	Theoretical Force at 87 PSI (lbs.)	Cushion Length (in.)	Max. Allowed Bending Moment Ma (in./lbs.)	Max. Allowed Bending Moment Ms (in./lbs.)	Max. Allowed Bending Moment Mv (in./lbs.)	Max. Allowed Load L (lbs.)
25	132	0.55	264	115	54	130
32	216	1.10	636	248	240	230
40	338	1.42	1150	444	312	390
50	530	1.50	2034	859	624	540

Double Piston Values

Cyl. Ø (mm)	Theoretical Force at 87 PSI (lbs.)	Cushion Length (in.)	Max. Allowed Bending Moment Ma (in./lbs.)	Max. Allowed Bending Moment Ms (in./lbs.)	Max. Allowed Bending Moment Mv (in./lbs.)	Max. Allowed Load L (lbs.)
25	132	0.55	672	230	90	260
32	216	1.10	1440	496	1200	460
40	338	1.42	2640	888	1584	780
50	530	1.50	4608	1718	2928	1080

Cushioning Diagram

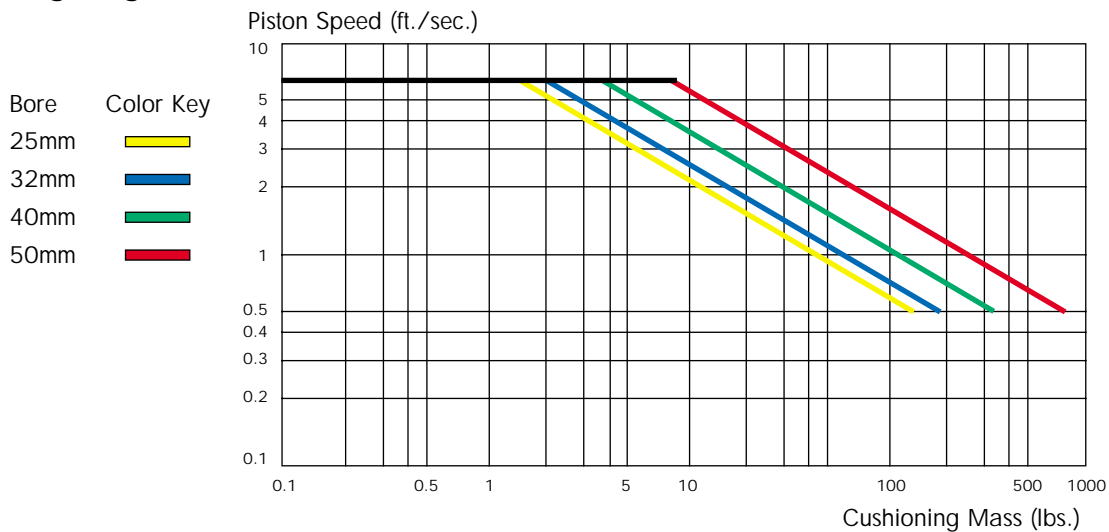

Piston Mountings

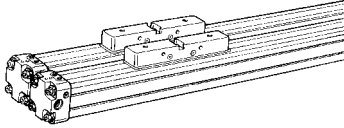
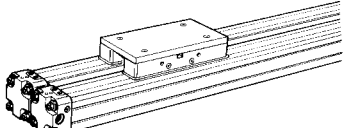
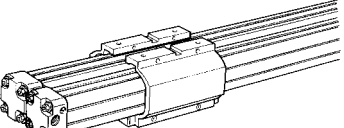
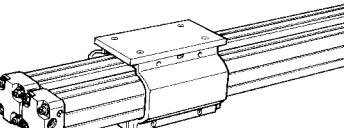
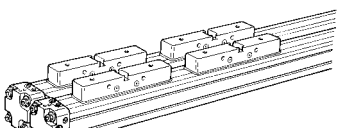
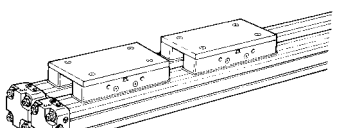
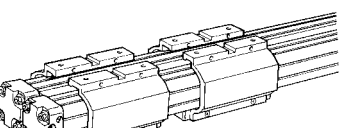
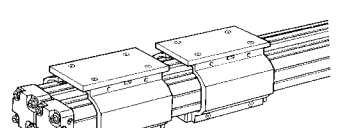
Designation	Pictorial Representation	Description	Cyl. Ø	Weight 0" stroke	Weight per inch
Type J2020/20		Piston Mounting NR20 Standard mounting. Mounted during cylinder assembly.	25	2.82	0.24
			32	6.84	0.46
			40	10.92	0.63
			50	16.50	0.97
Type J2020/24		Piston Mounting NR24 Flat, platform mounting. Provides a common connection across both pistons.	25	3.24	0.24
			32	7.72	0.46
			40	11.91	0.63
			50	18.70	0.97
Type J2020/30		Piston Mounting NR30 Transfers power to the back of the cylinder. Protects the band surface from foreign particles.	25	3.92	0.24
			32	9.26	0.46
			40	13.77	0.63
			50	22.00	0.97
Type J2020/34		Piston Mounting NR34 Combines the features of the NR24 mounting and the NR30 mounting.	25	4.34	0.24
			32	10.14	0.46
			40	14.76	0.63
			50	24.20	0.97
Type J2220/20		Piston Mounting NR20 Two pistons in each barrel using the standard NR20 mounting.	25	4.44	0.24
			32	11.11	0.46
			40	19.37	0.63
			50	28.60	0.97
Type J2220/24		Piston Mounting NR24 Two pistons in each barrel. Provides a common connection across each set of pistons.	25	5.28	0.24
			32	12.87	0.46
			40	21.35	0.63
			50	33.00	0.97
Type J2220/30		Piston Mounting NR30 Two pistons in each barrel using the NR30 mounting. Transfers power to the back of the cylinder.	25	5.54	0.24
			32	13.55	0.46
			40	21.76	0.63
			50	34.10	0.97
Type J2220/34		Piston Mounting NR34 Two pistons in each barrel Combines the features of the NR24 mounting and the NR30 mounting.	25	6.38	0.24
			32	15.31	0.46
			40	23.74	0.63
			50	38.50	0.97

Overall Dimensions

Basic Dimensions (Single Piston)

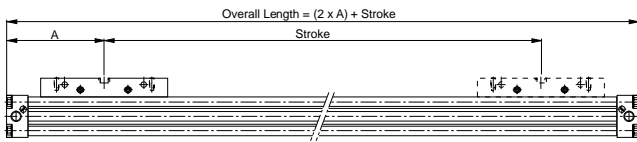

Basic Dimensions (Double Piston)

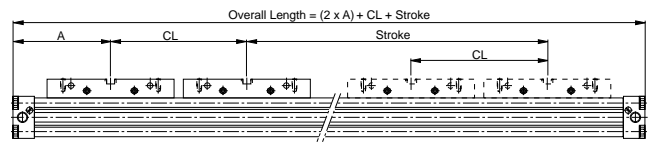

End Cap Cross Section

Alternate Cushion Position

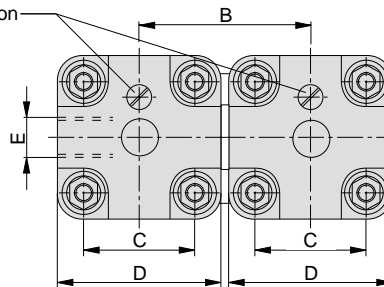

Piston Mounting NR24

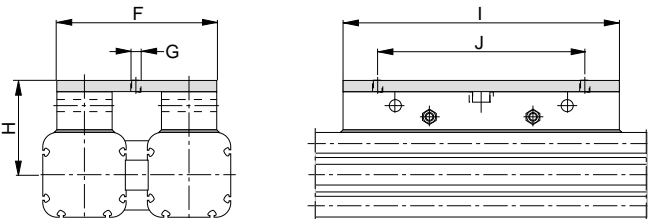

Cylinder Mounting NR8

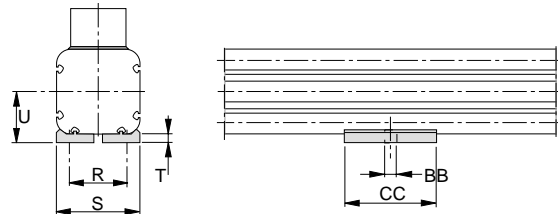

Piston Mounting NR34

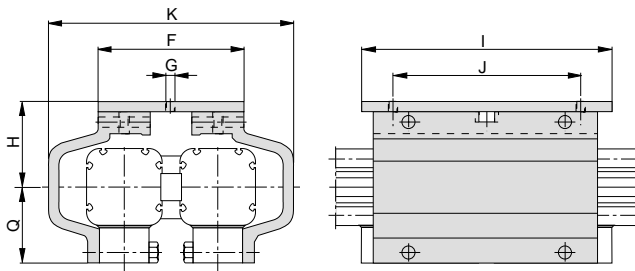

Cylinder Mounting NR17

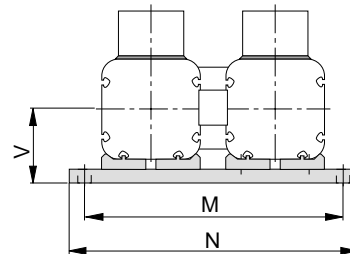

Cyl. Ø	A	B	C	D	E	F	G	H	I	J	K
25	3.94	1.73	1.06	1.57	1/8 NPT	2.76	1/4-20	1.81	4.72	3.15	4.72
32	4.92	2.20	1.42	2.09	1/4 NPT	3.54	5/16-18	2.28	6.30	4.73	5.98
40	5.91	2.60	1.81	2.48	1/4 NPT	3.94	5/16-18	2.52	6.30	4.73	6.86
50	6.70	3.19	2.13	3.07	3/8 NPT	4.73	3/8-16	3.15	7.88	6.30	8.31

Cyl. Ø	M	N	Q	R	S	T	U	V	BB	CC	CL(min.)
25	3.62	4.09	1.50	1.06	1.42	.21	.94	1.10	10-32	.79	5.12
32	4.81	5.44	1.89	1.42	1.89	.22	1.18	1.42	1/4-20	1.57	6.90
40	5.59	6.22	2.13	1.81	2.28	.22	1.38	1.61	1/4-20	1.57	8.75
50	6.89	7.68	2.56	2.13	2.83	.33	1.77	2.01	5/16-18	2.48	10.00

Cylinder Mountings

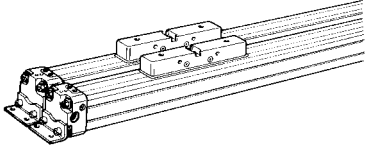
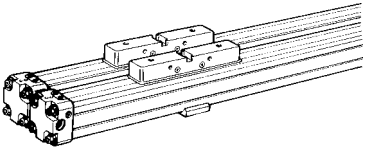
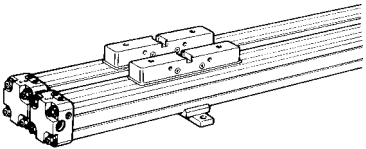
Designation	Pictorial Representation	Description	Cyl. Ø	Part Number	Weight (lbs.)
Type NR4		End Cap Mounting Provides rigid end mounting of the cylinder.	25	2172-0201	0.07
			32	2172-0351	0.11
			40	2172-0451	0.13
			50	2172-0551	0.26
Type NR8 (Ø 25mm - 50mm only)		Center Support Provides stability at cylinder center when heavy loads are traversed over long distances.	25	2175-0201	0.04
			32	2175-0351	0.07
			40	2175-0451	0.07
			50	2175-0551	0.26
Type NR17 (Ø 25mm - 50mm only)		Center Support Provides stability at cylinder center when heavy loads are traversed over long distances.	25	2736-0201	0.13
			32	2736-0351	0.25
			40	2736-0451	0.28
			50	2736-0551	0.84

Orientation Examples

Orientation #1

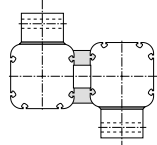

12-6 O'clock

Orientation #2

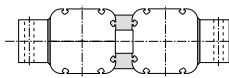

9-3 O'clock

Orientation #3

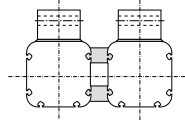

12-12 O'clock

Orientation #4

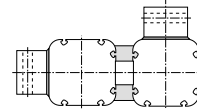

9-12 O'clock

Note: Joint Clamp cylinder loadings will vary depending on the above orientation used. Consult the factory for design assistance.

Series 2000 NR50

Bore sizes: 16mm, 25mm, 32mm, 40mm and 50mm
Stroke lengths available up to 480"

See OSP-P Series



Technical Data

Loads, forces, moments

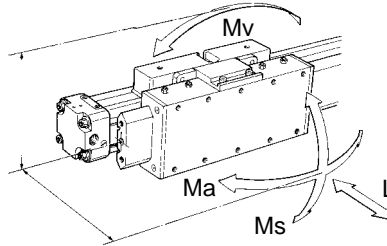

Single Piston Values

Cyl. Ø (mm)	Theoretical Force at 87 PSI (lbs.)	Cushion Length (in.)	Max. Allowed Bending Moment Ma (in./lbs.)	Max. Allowed Bending Moment Ms (in./lbs.)	Max. Allowed Bending Moment Mv (in./lbs.)	Max. Allowed Load L (lbs.)
16	27	0.59	100	54	100	81
25	66	0.55	252	216	252	325
32	108	1.10	576	504	576	500
40	169	1.42	792	648	792	575
50	265	1.50	1584	1080	1584	750

Double Piston Values

Cyl. Ø (mm)	Theoretical Force at 87 PSI (lbs.)	Cushion Length (in.)	Max. Allowed Bending Moment Ma (in./lbs.)	Max. Allowed Bending Moment Ms (in./lbs.)	Max. Allowed Bending Moment Mv (in./lbs.)	Max. Allowed Load L (lbs.)
16	27	0.59	230	108	230	162
25	66	0.55	580	432	580	650
32	108	1.10	1325	1008	1325	1000
40	169	1.42	1822	1296	1822	1150
50	265	1.50	3643	2160	3643	1500

Note: Above loading data is valid for traverse speeds not exceeding 8 in./sec.
For traverse speeds in excess of 8 in./sec. please consult the factory.

Cushioning Diagram

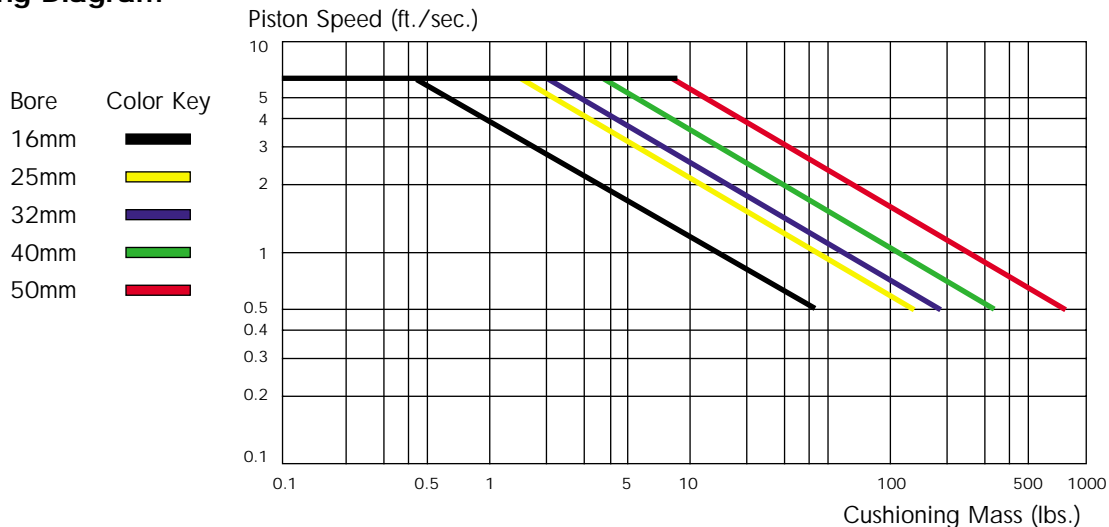

Piston Mountings

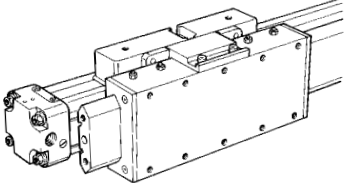
Designation	Pictorial Representation	Description	Cyl. Ø	Weight 0" stroke	Weight per inch
Type 2020/50		Piston Mounting NR50	25	3.37	0.20
		External Guide Option. Mounted during cylinder assembly or in-field retrofit.	32	6.97	0.36
			40	10.70	0.70
			50	16.20	1.06

Overall Dimensions (Ø25mm - Ø50mm)

See OSP-P Series

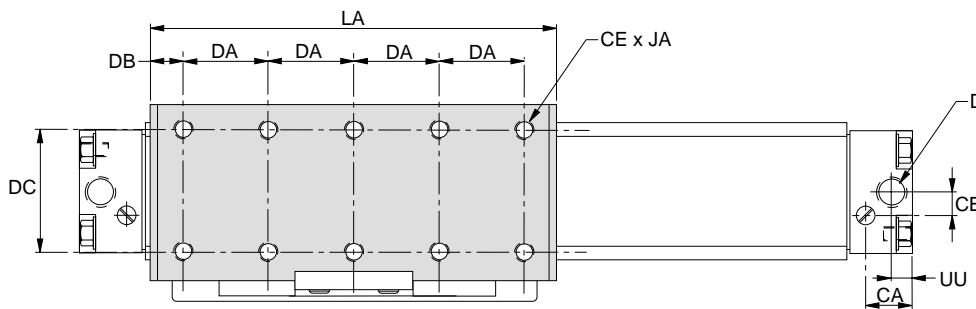

Double Piston Models

Min. C.L. Distances

Ø25mm =	6.12
Ø32mm =	7.90
Ø40mm =	9.75
Ø50mm =	11.50

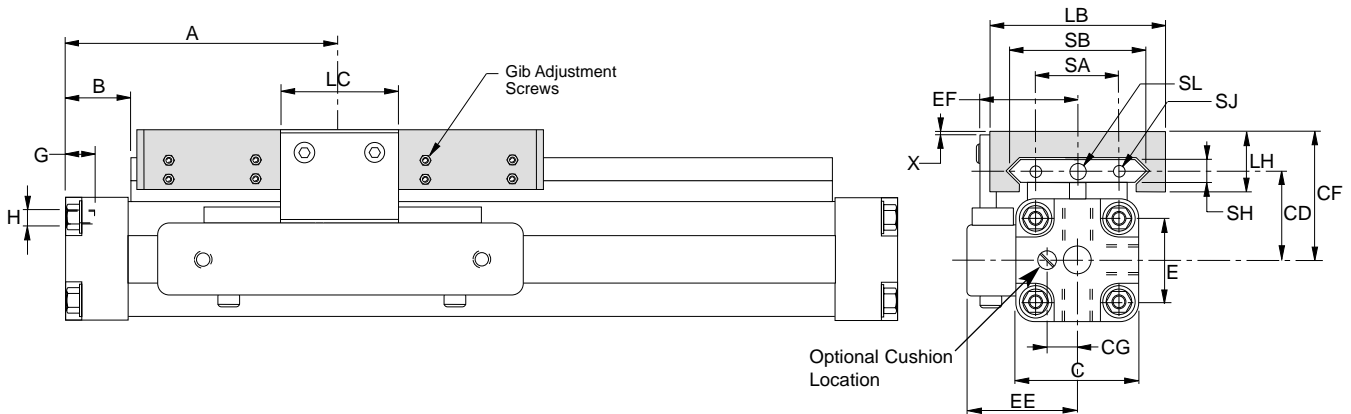

Cyl. Ø	A	B	C	D	E	G	H	CA	CB	CD	CE	CF	CG	DA	DB
25	3.94	.91	1.62	1/8 NPT	1.06	.35	10-32	.71	.26	1.26	1/4-20	2.05	.35	1.18	.55
32	4.92	1.06	2.09	1/4 NPT	1.42	.47	1/4-20	.83	.35	1.60	1/4-20	2.44	.51	1.57	.63
40	5.91	1.06	2.48	1/4 NPT	1.81	.47	1/4-20	.71	.51	1.80	1/4-20	2.63	.65	1.97	.67
50	6.70	1.26	3.07	3/8 NPT	2.13	.47	5/16-18	.83	.59	2.21	5/16-18	3.07	.73	2.36	.83

Cyl. Ø	DC	EE	EF	JA	LA	LB	LC	LH	SA	SB	SH	SJ	SL	UU	X
25	1.97	1.50	1.50	.39	5.83	2.52	1.57	1.18	1.10	1.85	.47	.16	.24	.33	.08
32	2.68	1.89	1.89	.47	7.56	3.31	2.17	1.30	1.38	2.64	.55	.24	.31	.41	.08
40	3.07	2.13	2.13	.47	9.21	3.70	2.17	1.30	1.97	3.03	.55	.24	.31	.41	.08
50	3.54	2.56	2.48	.47	11.10	4.33	2.56	1.34	2.20	3.58	.55	.24	.31	.49	.08

Piston Mountings

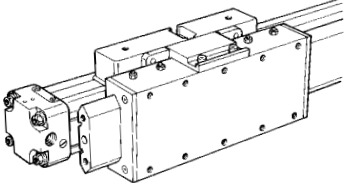
Designation	Pictorial Representation	Description	Cyl. Ø	Weight 0" stroke	Weight per inch
Type 2020/50		Piston Mounting NR50 External Guide Option. Mounted during cylinder assembly or in-field retrofit.	16	1.54	0.10

Overall Dimensions

See OSP-P Series

Double Piston Models

Min. C.L. Distances
Ø16mm = 4.50

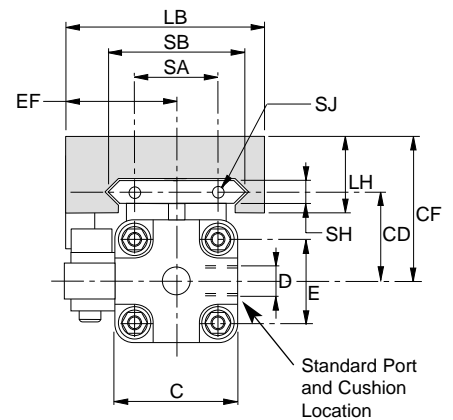
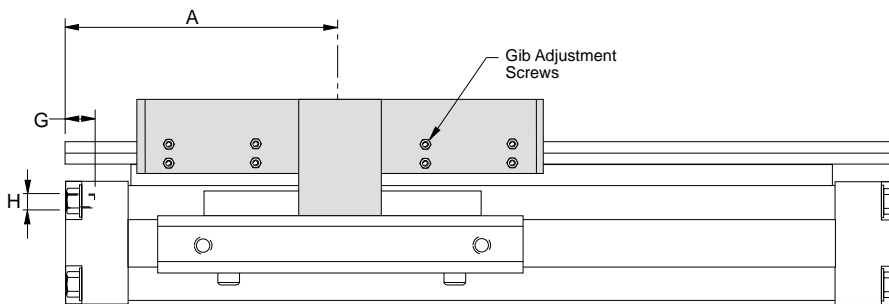
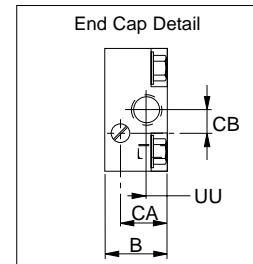
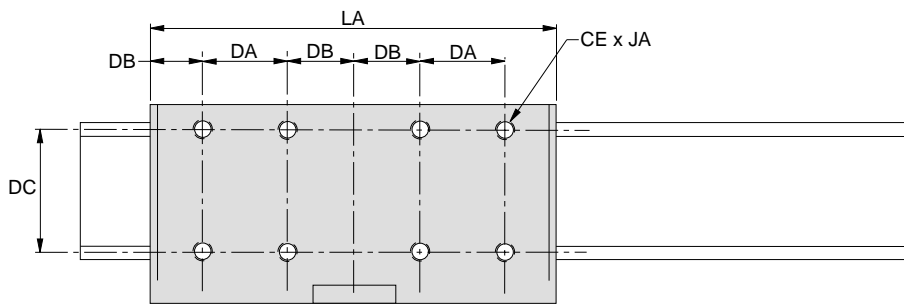

Cyl. Ø	A	B	C	D	E	G	H	CA	CB	CD	CE	CF	CG	DA	DB
16	2.56	.59	1.06	10-32	.71	.20	M3	.47	.19	.94	M4	1.73	---	.79	.59
Cyl. Ø	DC	EE	EF	JA	LA	LB	LC	LH	SA	SB	SH	SJ	SL	UU	X
16	1.42	---	1.18	.31	3.94	2.13	---	1.10	.71	1.42	.31	M3	---	.20	---

Series 2000
NR50

Cylinder Mountings

Designation	Pictorial Representation	Description	Cyl. Ø	Part Number	Weight (lbs.)
Type NR4		End Cap Mounting	16	2172-0101	0.02
			25	2172-0201	0.07
			32	2172-0351	0.11
			40	2172-0451	0.13
			50	2172-0551	0.26
Type NR7		Center Support	16	2176-0101	0.01
			25	2176-0202	0.07
			32	2176-0351	0.13
			40	2176-0451	0.15
			50	2176-0551	0.44
Type NR8 (Ø 25mm - 50mm only)		Center Support	25	2175-0201	0.04
			32	2175-0351	0.07
			40	2175-0451	0.07
			50	2175-0551	0.26

Dimensions

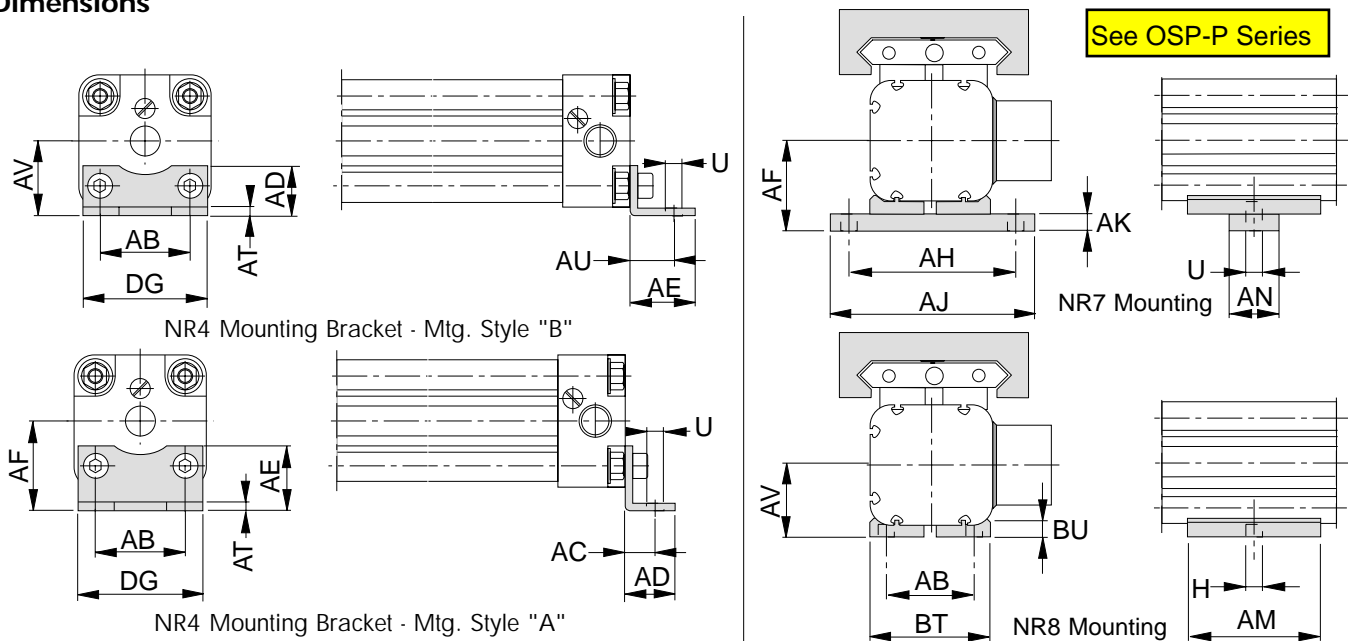

Cyl. Ø	U	AB	AC	AD	AE	AF	AH	AJ	AK	AM	AN	AT	AU	AV	BT	BU	DG	H
16	.14	.71	.39	.55	.49	.59	1.26	1.57	.18	-	.47	.06	-	-	-	-	1.02	-
25	.22	1.06	.41	.71	.87	1.10	1.89	2.36	.16	1.26	.79	.08	.57	.94	1.42	.21	1.54	10-32
32	.26	1.42	.47	.79	1.02	1.42	2.60	3.23	.24	1.57	.79	.12	.71	1.18	1.89	.22	1.97	1/4-20
40	.26	1.81	.47	.79	1.02	1.61	2.99	3.62	.24	1.57	.79	.12	.71	1.38	2.28	.22	2.36	1/4-20
50	.35	2.13	.71	1.10	1.34	2.01	3.70	4.49	.24	2.48	1.57	.16	.94	1.77	2.83	.33	2.91	5/16-18

Series 2000 Powerguide™

Bore sizes: 25mm, 32mm and 50mm
Stroke lengths available up to 120". Longer strokes available upon request.

See OSP-P Series



The Powerguide Principle

The Powerguide comprises two proven technologies, an ORIGA rodless cylinder and a HEPCO precision ball bearing based slideway. The result is a prime mover and guide combined, providing optimum linear precision and load capacity to satisfy the most demanding applications across a broad industry base. This simple method of providing controlled linear movement eliminates the need for separate supports and guidance hardware, so reducing design and manufacturing costs.

SYSTEM FEATURES:

- Prime mover and guide combined.
- Equal load capacity in all directions.
- Hardened slideway for long life.
- Precision double row bearings for maximum loads and rigidity.
- Purpose made carriage plate has a large adaptable mounting surface.
- Suitable for harsh environments.
- Requires no additional support hardware.
- High speed and cycle capability.
- Factory-set adjustable bearings to eliminate play.

Technical Data

Loads, forces, moments

See OSP-P Series

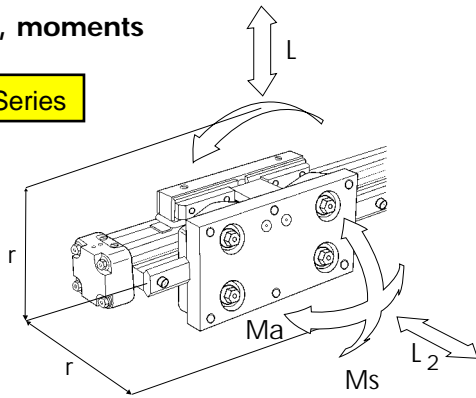

$M_a = F \cdot r$
 $M_s = F \cdot r$
 $M_v = F \cdot r$

The maximum moment and direct load capacities are given in the table below. To calculate the life of a given Powerguide the LOAD FACTOR L_F should be calculated using the equation below.

$$L_F = \frac{M_a}{M_a \text{ (max.)}} + \frac{M_s}{M_s \text{ (max.)}} + \frac{M_v}{M_v \text{ (max.)}} + \frac{L_1}{L_1 \text{ (max.)}} + \frac{L_2}{L_2 \text{ (max.)}}$$

L_F should not exceed 1 for any combination of loads.

Cyl. Ø	Force (lbs. f) at 87 PSI	Cushion Length (in.)	Max. Allowed Moment Load (in.-lbs.)		Max. Allowed Torque (in.-lbs.) Mv	Max. Allowed Direct Load (lbs.)		Powerguide Weight (lbs.) for 0" stroke increase ea. add. in.	
			Ma	Ms		L1	L2		
25	66	.55	451	98	451	263	263	3.75	.24
32	108	1.10	1200	451	1200	526	526	6.83	.43
50	265	1.50	3850	1566	3850	900	900	24.23	.85

Relating load applied to life

It is important to satisfy both load and life requirements when looking at an application. In many instances it will not be necessary to calculate the life of a system, but if a high number of strokes coupled with a heavy load are evident then life can be an important factor. This is also particularly relevant in short stroke or moment load applications. (See LOAD/LIFE example below)

Note: LOAD/LIFE capacities are based on linear speeds up to 5 feet/sec. and lubrication being evident at the bearing and slide contact faces.

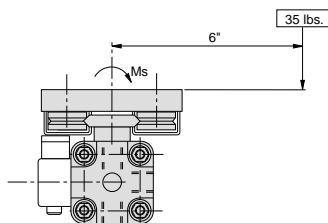
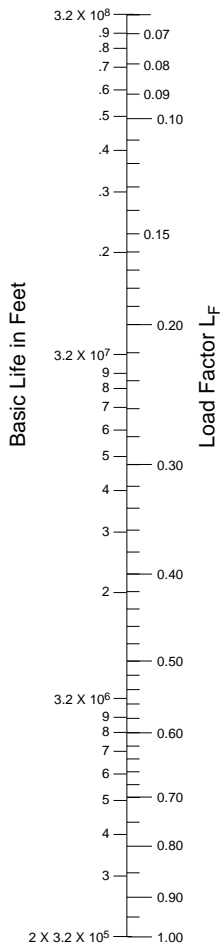

Example: 32-2020/PG (at left)
 Moment $M_s = 35 \text{ lbs.} \times 6 = 210 \text{ in.-lbs.}$
 $L_2 = 35 \text{ lbs.}$

Applying formula

$$L_F = \frac{M_s}{M_s \text{ (max.)}} + \frac{L_2}{L_2 \text{ (max.)}}$$

$$L_F = \frac{35}{451} + \frac{35}{526} = .532$$

Basic Life $\geq (3.2 \times 10^6) = 3,200,000$ Feet

Cushioning Diagram

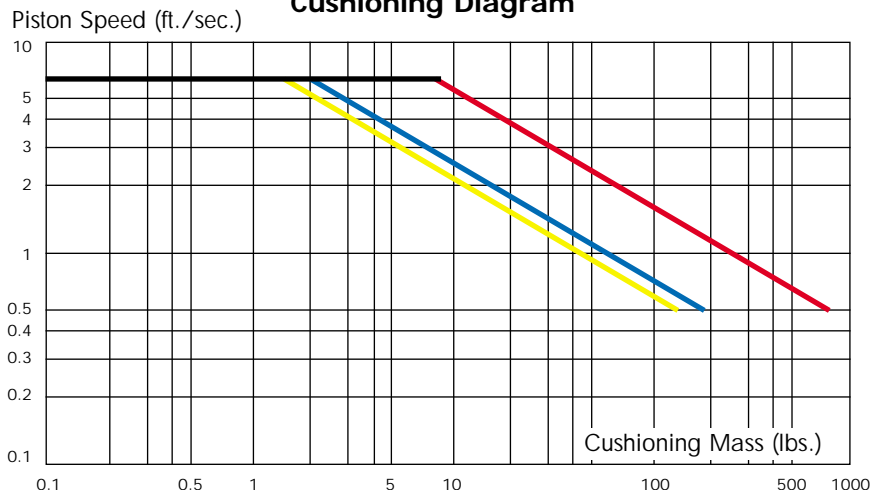

Piston Mountings

Ø 25mm, 32mm and 50mm

See OSP-P Series

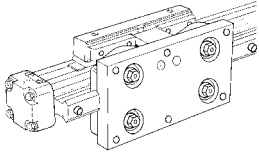
Designation	Pictorial Representation	Description	Cyl. Ø	Weight 0" stroke (lbs.)	Weight per inch (lbs.)
Type 2020/PG		Piston Mounting PG	25	3.75	0.95
		Standard mounting. Mounted during cylinder assembly.	32	6.80	0.44
			50	19.50	0.90

Overall Dimensions

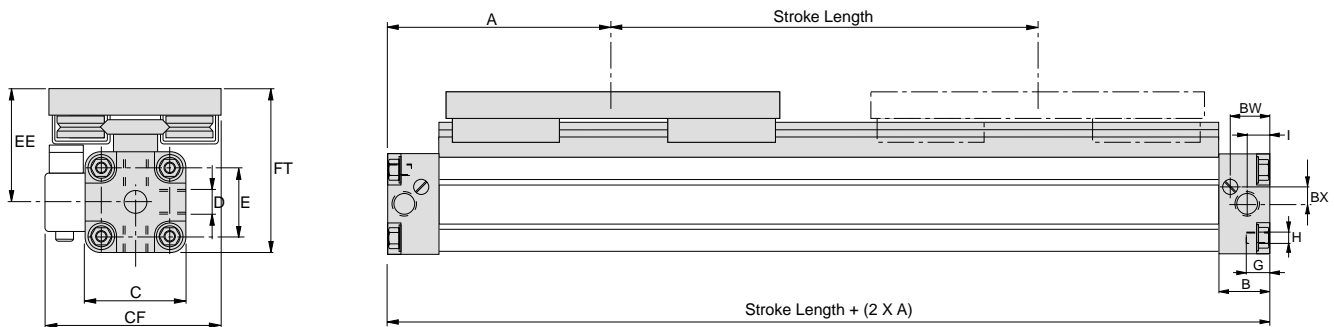

Cyl.Ø	A	B	C	D	E	G	H	I	BW	BX	CF	EE	FT
25	3.94	.91	1.57	1/8	1.06	.35	10-32	.33	.71	.26	3.31	2.09	2.87
32	4.92	1.06	2.05	1/4	1.42	.55	1/4-20	.41	.85	.35	4.45	2.52	3.54
50	6.70	1.26	3.07	3/8	2.13	.47	5/16-18	.49	.83	.59	6.20	3.66	5.20

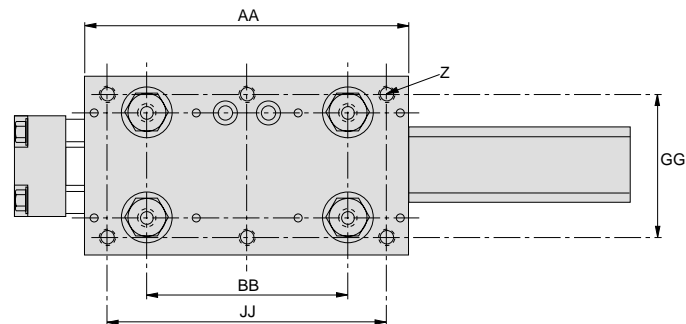
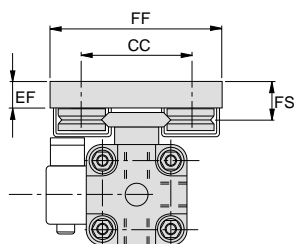

Cyl.Ø	Z	AA	BB	CC	EF	FF	FS	GG	JJ
25	1/4-20	5.71	3.54	1.85	.51	3.15	.87	2.52	4.92
32	5/16-18	7.48	4.65	2.87	.59	4.57	1.02	3.78	6.46
50	3/8-16	11.02	6.89	4.71	.83	7.28	1.58	6.00	10.00

Dimensions - Cylinder Mountings - Powerguide™

See OSP-P Series

NR4 Mounting
Mtg. Style "A"

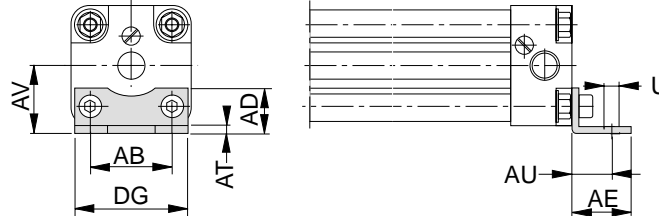

Note: Part numbers
see page 3.3/4
NR4

NR4 Mounting
Mtg. Style "B"

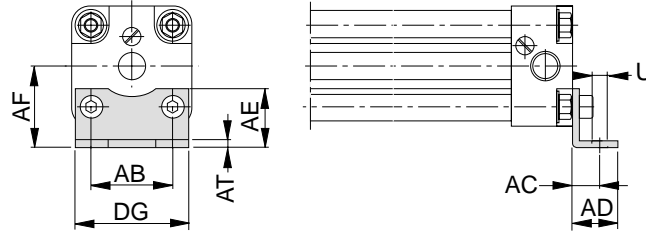

Note: Part numbers
see page 3.3/4
NR4

NR7 Mounting

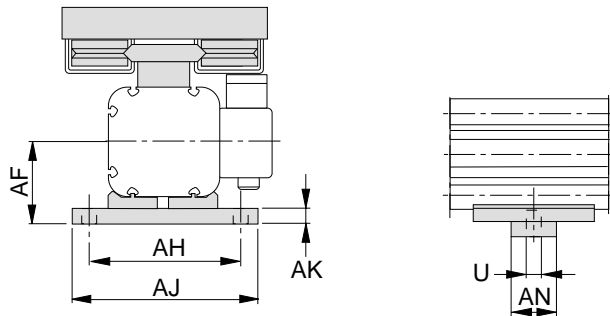

Note: Part numbers
see page 3.3/4
NR7

NR3 Mounting

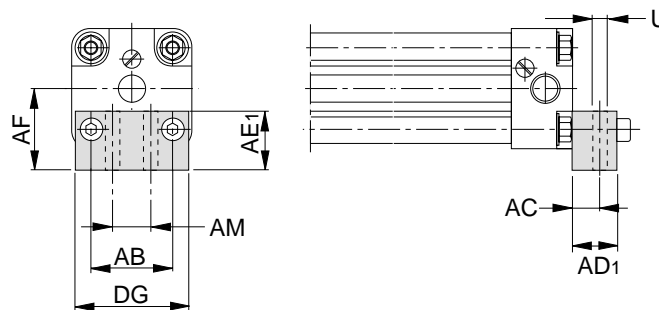

Bore	Part Number
25	2170-0201
32	2170-0301
50	2170-0501

Cyl. Ø	U	AB	AC	AD	AD ₁	AE	AE ₁	AF	AH	AJ	AK	AM	AN	AT	AU	AV	DG
25	.22	1.06	.41	.71	.75	.87	1.00	1.10	1.89	2.36	.16	0.50	.79	.08	.57	.94	1.54
32	.26	1.42	.47	.79	.75	1.02	1.00	1.42	2.60	3.23	.24	0.75	.79	.12	.71	1.18	1.97
50	.35	2.13	.71	1.10	1.00	1.34	1.25	2.01	3.70	4.49	.24	1.25	1.57	.16	.94	1.77	2.91

Series P120

Bore sizes: 40mm, 63mm and 80mm
Stroke lengths available up to 480"

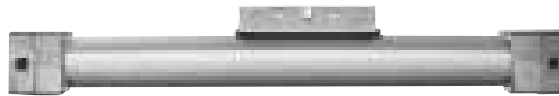

Technical Data

Loads, forces, moments

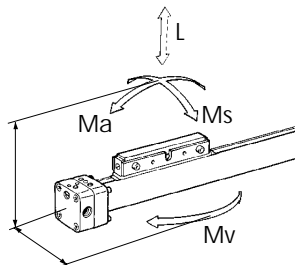

Short Piston Values

Cyl. Ø (mm)	Theoretical Force at 87 PSI (lbs.)	Cushion Length (in.)	Max. Allowed Bending Moment Ma (in./lbs.)	Max. Allowed Bending Moment Ms (in./lbs.)	Max. Allowed Bending Moment Mv (in./lbs.)	Max. Allowed Load L (lbs.)
40	169	1.26	528	36	72	170
63	420	1.57	1776	72	216	370
80	677	1.73	3192	144	420	590

Long Piston Values

Cyl. Ø (mm)	Theoretical Force at 87 PSI (lbs.)	Cushion Length (in.)	Max. Allowed Bending Moment Ma (in./lbs.)	Max. Allowed Bending Moment Ms (in./lbs.)	Max. Allowed Bending Moment Mv (in./lbs.)	Max. Allowed Load L (lbs.)
40	169	1.26	1200	72	216	170
63	420	1.57	3984	144	660	370
80	677	1.73	6372	288	1236	590

Values are based on light, shock-free duty and should not be exceeded during piston acceleration.

Cushioning Diagram

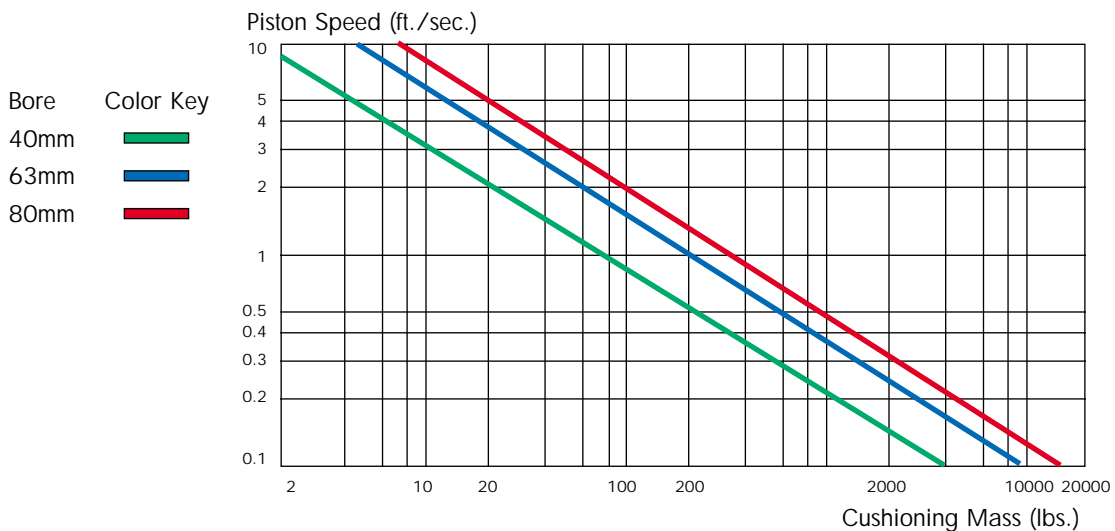

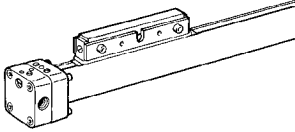
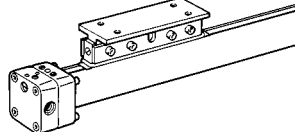
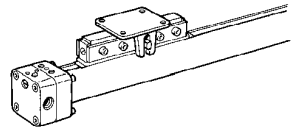
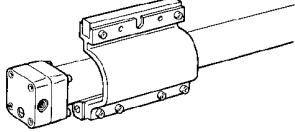
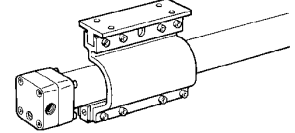
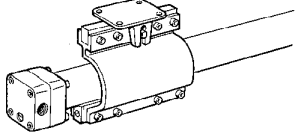
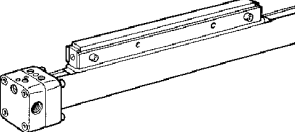
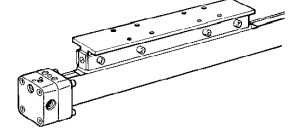
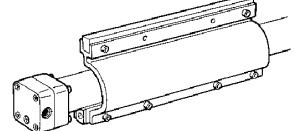
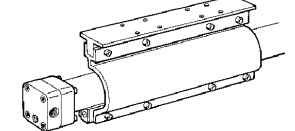
Designation	Pictorial Representation	Description	Cyl. Ø	Weight 0" stroke	Weight per inch
Type P120-S/20		Piston Mounting S/20 Standard mounting. Mounted during cylinder assembly.	40	7.26	0.20
			63	20.46	0.45
			80	35.42	0.71
Type P120-S/22		Piston Mounting S/22 Flat, platform mounting	40	7.48	0.20
			63	20.90	0.45
			80	36.74	0.71
Type P120-S/25		Piston Mounting S/25 Allows for a floating connection between the cylinder and an externally guided device.	40	7.92	0.20
			63	22.66	0.45
			80	38.06	0.71
Type P120-S/30		Piston Mounting S/30 Transfers power to the back of the cylinder. Protects the band surface from foreign particles.	40	9.24	0.20
			63	25.74	0.45
			80	44.88	0.71
Type P120-S/32		Piston Mounting S/32 Combines the features of the S/22 mounting and the S/30 mounting.	40	9.46	0.20
			63	26.18	0.45
			80	46.20	0.71
Type P120-S/35		Piston Mounting S/35 Combines the features of the S/25 mounting and the S/30 mounting.	40	9.90	0.20
			63	27.94	0.45
			80	47.52	0.71
Type P120-L/26		Piston Mounting L/26 Standard mounting. Mounted during cylinder assembly.	40	11.00	0.20
			63	30.58	0.45
			80	51.04	0.71
Type P120-L/28		Piston Mounting L/28 Flat, platform mounting.	40	11.44	0.20
			63	32.12	0.45
			80	53.68	0.71
Type P120-L/36		Piston Mounting L/36 Transfers power to the back of the cylinder. Protects the band surface from foreign particles.	40	14.74	0.20
			63	42.02	0.45
			80	70.40	0.71
Type P120-L/38		Piston Mounting L/38 Combines the features of the L/28 mounting and the L/36 mounting.	40	15.18	0.20
			63	43.56	0.45
			80	73.04	0.71

Overall Dimensions

Basic Dimensions

Overall Length = Stroke + (2 X A)

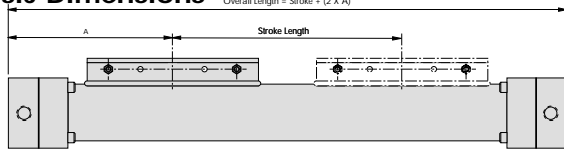

End Cap Dimensions

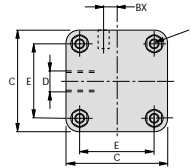

Piston Mounting S/20

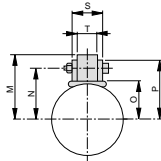
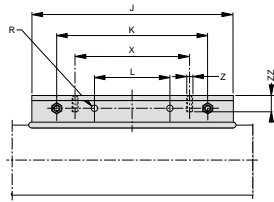

Piston Mounting L/26

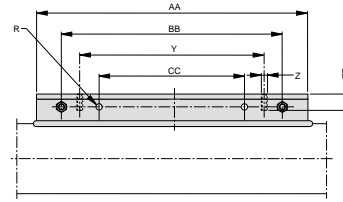

Piston Mounting S/22

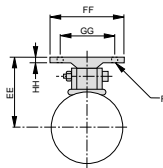
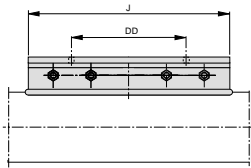

Piston Mounting L/28

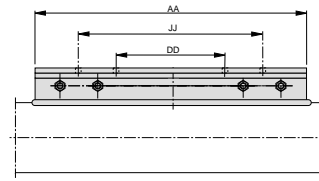

Piston Mounting S/25

S/30

L/36

Piston Mounting S/35

S/32

L/38

Cyl. Ø	A (S)	A (L)	B	C	D	E	F	G	H	I	J	K	L	M	N	O	P	R		
40	5.91	9.91	2.36	2.83	1/4 NPT	2.13	2.28	.59	1/4-20	.59	5.91	4.33	2.17	2.40	1.93	1.28	2.24	.28		
63	8.46	14.46	3.15	4.17	3/8NPT	3.07	3.46	.79	5/16-18	.79	8.66	7.09	3.54	3.27	2.68	1.89	3.07	.35		
80	10.24	16.24	3.94	5.20	1/2NPT	3.78	4.41	.98	3/8-16	.98	11.02	9.45	4.72	3.98	3.27	2.36	3.74	.43		
Cyl. Ø	S	T	V	Y	AA	AR	AS	BB	BC	BD	BE	BF	BG	BH	BJ	BK	BL	BM	BN	
40	1.10	.71	.47	7.09	11.81	.31	3.31	9.45	5.43	11.34	3.35	2.30	2.87	3.19	2.09	1.65	1.89	3.54	3.90	
63	1.18	.75	.63	11.81	18.90	.39	3.54	15.75	8.19	18.43	4.61	3.23	4.02	4.41	3.03	2.44	2.80	4.84	5.28	
80	1.26	.79	.79	14.17	22.05	.51	4.33	18.90	10.55	21.57	5.63	4.02	4.92	5.39	3.78	3.07	3.46	5.91	6.42	
Cyl. Ø	BP	BW	BX	CC	DD	EE	FF	GG	HH	JJ	KK	LL	MM	NN	PP	RR	SS	TT	ZZ	α
40	2.95	.59	.43	4.72	3.15	2.60	2.36	1.77	.24	6.30	2.95	2.00	1.26	±.32	2.76	2.17	3.54	2.95	.47	22°
63	4.11	.79	.59	7.87	5.12	3.50	3.15	2.36	.28	10.24	3.94	2.76	1.54	±.39	3.54	2.76	4.72	3.94	.63	15°
80	5.04	.98	.63	9.45	7.09	4.25	3.94	2.95	.31	14.17	4.80	3.39	1.89	±.47	4.33	3.35	5.91	4.92	.79	15°

Cylinder Mountings

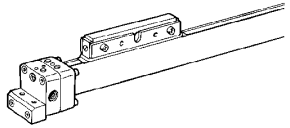
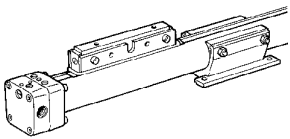
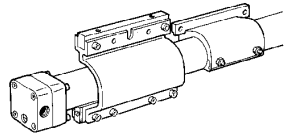
Designation	Pictorial Representation	Description	Cyl. Ø	Part Number	Weight (lbs.)
Type NR3		End Cap Lug Mount	40	2170-0451	0.22
			63	2170-0651	0.66
			80	2170-0851	1.32
Type NR7		Center Support	40	2176-0402	1.32
			63	2176-0602	3.74
			80	2176-0802	6.38
Type NR9		Center Support	40	2177-0401	1.32
			63	2177-0601	3.74
			80	2177-0801	7.26

End Cap Lug Mount NR3

Center Support NR7

Position of Cylinder Mountings

Center Support NR9

Cyl. Ø	C	R	U	AB	AC	AD	AE	AF	AG	AH	AJ	AK	AL	AM	AN	AP	BR	BS	BY
40	2.83	.28	.35	1.18	.49	.94	.94	1.50	2.99	2.76	3.35	.31	2.32	4.72	6.30	5.71	3.15	.83	1.50
63	4.17	.35	.43	1.89	.59	1.18	1.57	2.24	4.49	3.74	4.49	.39	3.50	6.30	8.27	7.48	3.94	1.26	2.24
80	5.20	.43	.55	2.36	.69	1.38	1.97	2.83	5.67	4.72	5.67	.47	4.41	7.87	10.23	9.25	4.72	1.57	2.83

Proximity Switches RS (Reed Switch)

General

Pneumatic systems can often be combined with electric control circuits. The position of the piston in the cylinder can then be sensed by means of a proximity switch which delivers signals to the control system. The ORIGA type RS proximity switch is a non-contacting, electric sensor integrated with the cylinder. No external cams or other mechanical actuating devices are necessary. The cylinder, incorporating the required number of switches, is a complete unit which is ready for installation.

Operation

The type RS proximity switch consists of a reed switch which is actuated by a permanent magnet in the piston. The snap action of the contacts on closure ensures distinct and reliable operation.

Design

The reed switch is encapsulated and is enclosed in an aluminium case, to which the connecting cables are securely clamped. The design is very sturdy and the reed switches used can withstand high mechanical and electrical loads. The proximity switch consists of an encapsulated reed switch and an associated mounting. The proximity switches can therefore be very easily adjusted to operate at the required point along the piston stroke. All parts of the proximity switch are made of corrosion resistant materials.

Accuracy

The accuracy of a control system is dependent on the repeatability, hysteresis and dynamic error of the components. The repeatability of the reed switches used for the ORIGA proximity switches is excellent - .0004 in. In practice, the repeatability of a control system is determined by other components, such as by the variations in the operating points of associated relays and valves. The variations in the operating points of relays, valves and sensors are additive. Hysteresis is the directional dependence of the operating point, i.e. the switch is actuated at a slightly different piston position when the piston is moving in one direction than it is when the piston is moving in the opposite direction. An inherent feature of the reed switch is that the distance between these operating points is large. If an identical operating point is required, regardless of the direction of travel, two proximity switches - one on each side of the cylinder - can be used. These switches

can then be connected across logic circuits which will select the appropriate switch when the piston is moving to the right or to the left. Positional deviations in the positioning of the piston, for instance, will occur when the piston speed, its load or the compressed air supply pressure is varied (dynamic error).

Electrical Useful Life

The electrical useful life of the reed switch is determined by a number of factors, such as the breaking load, type of load and the type of electric power. The reed switches used have a high nominal rating of 35 watts ($\varnothing 10:10$ Watt). The electrical useful life is normally $3 - 6 \times 10^6$ switching operations at 35 Watt ($\varnothing 10:10$ Watt). At a lower load, the useful life is extremely high (more than 100×10^6 switching operations). The transients occurring in switching inductive loads (relay coils, solenoid valves, contactors) should be suppressed by means of diodes, RC circuits or varistors (voltage-dependent resistors). A diode connected in parallel with the load offers an inexpensive and reliable method of spark-suppression, although this can only be used on D.C. RC circuits and varistors can be used for A.C. and D.C., but these are more expensive and must be carefully matched to the circuit. Note that all types of spark-suppression devices across solenoid valves and relays cause some measure of drop-out delay. In the case of resistive loading with high inrush current (such as incandescent lamps), a protective resistor should be fitted in series with the load. Protective resistors should also be used when the cables are very long and the voltage is in excess of 100 V.

For the above reasons, a universal instrument (ohmmeter) or LEDs should be used for adjustment and checking of ORIGA proximity switches.

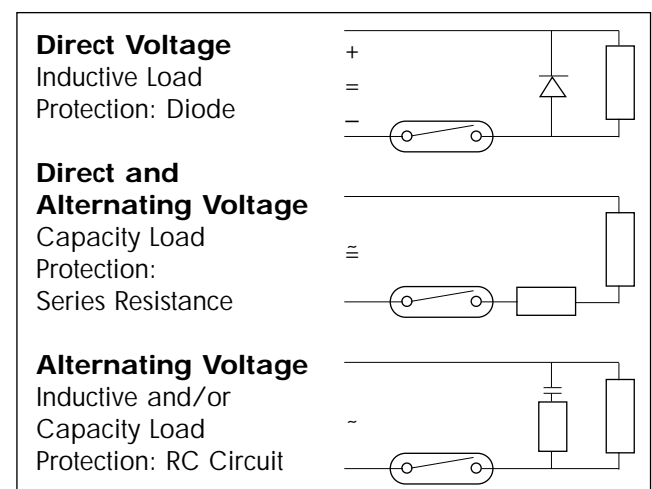

Technical Data

Proximity Switch RS

Manufacturer	ORIGA
Type	RS
Switching Configuration	Normally Open
Maximum Contact Rating	35 Watts (Ø 10mm = 10 Watts)
Maximum Voltage	250 Volts AC/DC
Maximum Starting Current	1.5 Amps (Ø 10mm = .5 Amps)
Hysteresis (integral)	Approx. 8mm
Temperature Range	-20° F to +175° F
Enclosure Class	IP 65
Housing Material	Anodized Aluminum

obsolete - please contact customer service at Hoerbiger-Origa

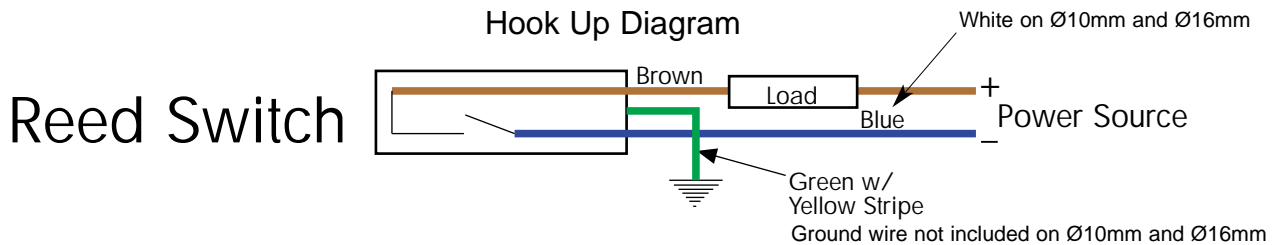

Reed Switches (RS) - Series 2000 (ref. page 4.1/5)

Designation		Bore Sizes					
		10mm	16mm	25mm	32mm	40mm	50mm
Type RS (without LED)	Part Number	3047	1723	2676-0201/5	2676-0301/5	2676-0301/5	2676-0501/5
5 Meter Cable							
Type RS (with LED)	Part Number	N/A	N/A	N/A	2690-0301/5	2690-0301/5	2690-0501/5
5 Meter Cable							
Sensor Clamp w/Set Screw	Part Number	N/A	1271	2689-0201	N/A	N/A	N/A

Ordering Procedure - Reed Switches (RS) - Series P120 (ref. page 4.1/7)

Series P120

RSQ-120

Switch Type: _____
RSA, RSD, RSF, RSQ

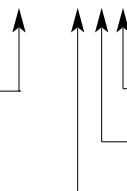

Switch Qty. - Second Track

Switch Qty. - First Track

Number of tracks:
1 = Left side (port side)
2 = Left and right side

Proximity Switches IS (Hall Effect Switch with LED)

General

Pneumatic systems can often be combined with electric control circuits. The position of the piston in the cylinder can then be sensed by means of a proximity switch which delivers signals to the control system.

The ORIGA Type IS proximity switch is a non-contacting electric sensor integrated with the cylinder. No external cams or other mechanical actuating devices are necessary. The cylinder, incorporating the required number of switches, is a complete unit which is ready for installation.

Operation

The basic principle of the hall effect sensing element is a high frequency oscillator circuit which is influenced by the magnetic field of the piston. With a defined magnetic field density the bounce free output signal is supplied via a flip-flop and an output stage and is indicated by the LED. The output signal can be processed into a control signal and is particularly suitable for signal input in programmable controllers.

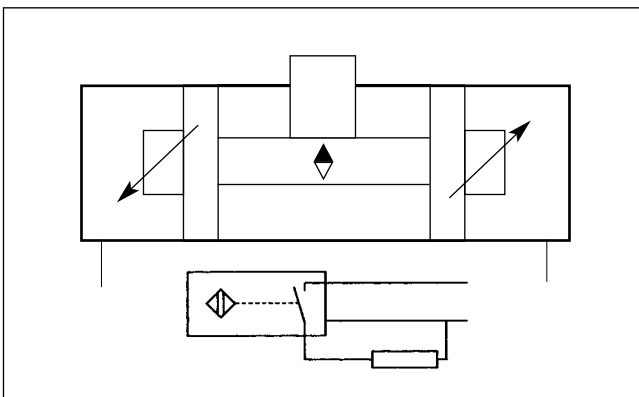

Advantages

Full electrical operation—no moving parts—wear free. Bounce-free signal output. Unaffected by shaking and vibration. High switching frequency. Built-in LED. Short circuit protected switching output with integral protective circuit. Low switching hysteresis.

Design

The IS switch is enclosed in an aluminium case to which the connecting cables are securely clamped. The proximity switch and its associated mounting

clamp is mounted in the grooves along the cylinder. The proximity switches can therefore very easily be adjusted to operate at the required point along the piston stroke. All parts of the proximity switch are made of corrosion resistant materials.

Accuracy

The accuracy of a control system is dependent on the repeatability, hysteresis and dynamic error of the components. The repeatability of the hall effect switches used for the ORIGA IS proximity switches is excellent - .0004 in. In practice the repeatability of a control system is determined by other components such as by the variations in the operating points or relays and valves and sensors are additive. Hysteresis is the directional dependency of the operating point i.e. the switch is actuated at slightly different piston position when the piston is moving in one direction than it is when the piston is moving in the opposite direction. With hall effect switches the difference between those operating points is very small. If an identical operating point is required, regardless of the direction of travel, two proximity switches (one on each side of the cylinder) can be used. These switches can then be connected across logic circuits which will select the appropriate switch when the piston is moving to the right or the left. Positional deviations in the positioning of the piston, for instance, will occur when the piston speed, its load or the compressed air supply pressure is varied (dynamic error).

Electrical Service Life

Because of the fully electronic mode of operation the electrical service life is theoretically unlimited. The IS sensor has integrated protection against inductive voltage peaks and is short circuit protected. Electrical protective circuits are not required.

Connection Diagram

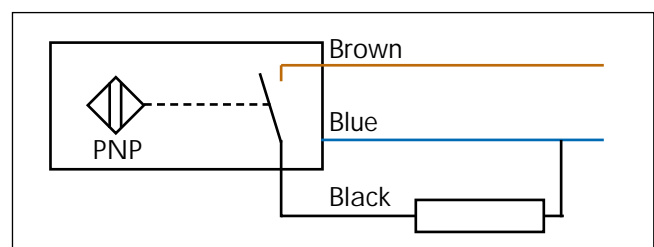

Technical Data

Proximity Switch (Hall Effect)

Manufacturer	ORIGA
Type	IS
Switching Configuration	Normally Open
Output Type	PNP
Maximum Continuous Current	200 mA
Maximum Voltage	10 - 30 Volt DC
Switch Indicator	LED
Maximum Closing Frequency	1 kHz (approx.)
Maximum Starting Current	1.5 Amps (Ø 10mm = .5 Amps)
Hysteresis (mounted)	Approx. .8mm
Temperature Range	-20° F to +175° F
Enclosure Class	IP 67
Housing Material	Anodized Aluminum
Connection Cable	3 X .25mm ²

Note: Connection leads are polarity protected.
Protection against inductive voltage peaks.
Short circuit protected.

Hall Effect

Hook Up Diagram

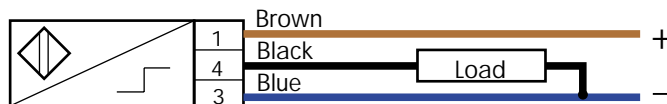

PNP (Sourcing)

Hall Effect

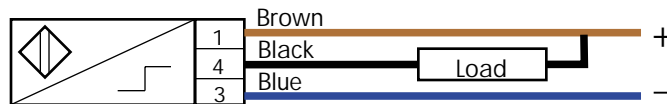

NPN (Sinking)

Inductive Switches (IS) - Series 2000/PowerGuide

Designation		Bore Sizes					
		10mm	16mm	25mm	32mm	40mm	50mm
Type IS PNP (with LED)	Part Number	3049	1724	0223*	0223-0301*	0223-0301	0223-0501
5 Meter Cable							
Type IS NPN (with LED)	Part Number	3753	3754	3755*	3755-0301*	3755-0301	3755-0501
5 Meter Cable							
Sensor Clamp	Part Number	N/A	1271	2689-0201*	2689-0301	2689-0301	2689-0501
w/Set Screw							

*Note: For 32mm PowerGuide cylinders use 25mm sensors and clamp.

Proximity Switch Series 2000 cylinders

For non-contact sensing of piston position on Origa rodless cylinders.

Type IS (Hall Effect Switch)

Available for Ø 10mm, 16mm and 50mm

- Proximity switch with cable connection for sensing end or intermediate positions.
- LED indicator
- Cable length 16 ft.

Ø10mm

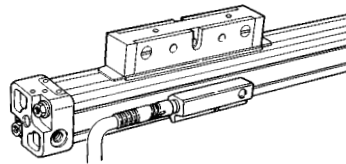

Ø16mm - 50mm

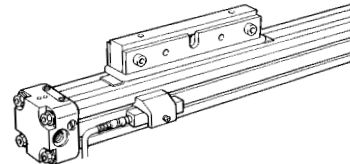

Type RS (Reed Switch)

Available for Ø 10mm, 16mm, 25mm, 32mm, 40mm and 50mm

- Proximity switch with cable connection for sensing end or intermediate positions.
- Cable length 16 ft.

Ø10mm

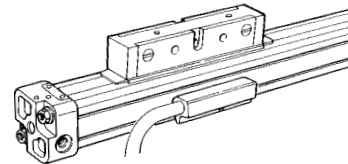

Ø16mm

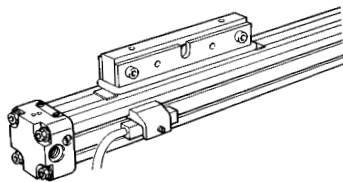

Ø25mm

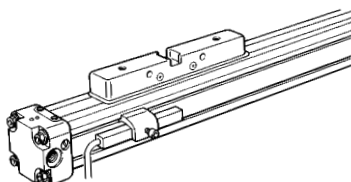

Ø32mm - 50mm

Advantages of Proximity Switches (RS and IS)

Simple Installation

The proximity switch is clamped in the required position simply by means of the clamp attachment. The sensor and clamp fit anywhere along the barrel grooves as illustrated in the above drawing.

Compact

The proximity switches are mounted directly to the side of the barrel and require minimal additional space - compact in design, the overall length of the cylinder does not change.

Safe in Operation

The proximity switch encapsulated in the aluminum housing has IP 65 (RS) and IP 67 (IS) protection and therefore can be used under adverse environmental conditions.

Cost Effective

Eliminates the need for cam and switch mountings. Maintenance free, no wearing parts.

Dimensions

Ø10mm

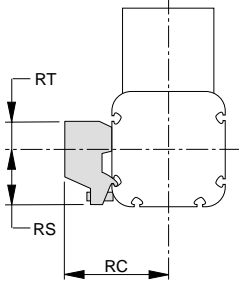

Ø10mm (IS)

Ø10mm (RS)

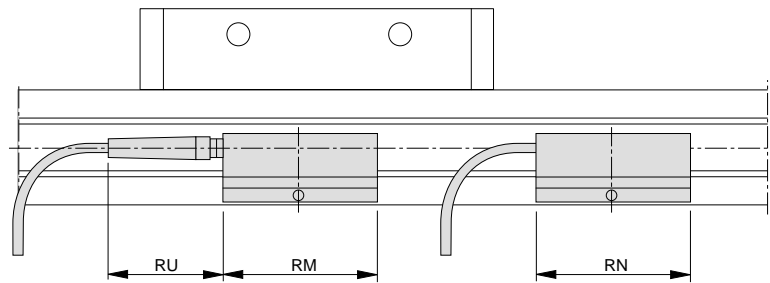

Ø16mm

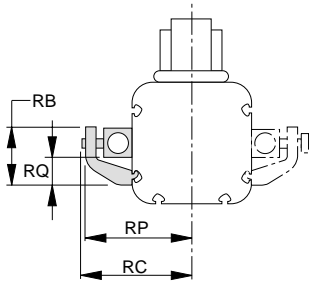

Ø16mm (IS)

Ø16mm (RS)

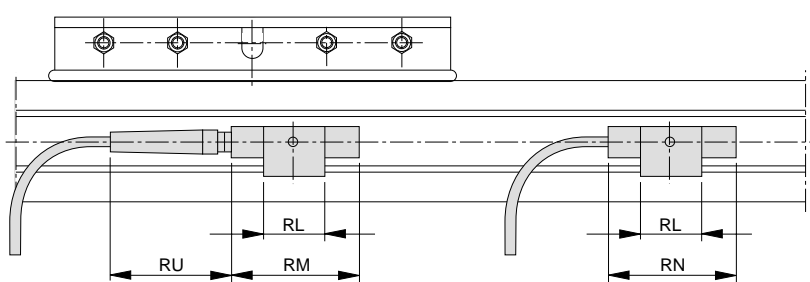

Ø25mm - Ø50mm

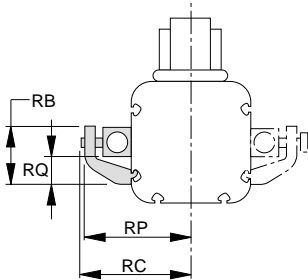

Ø25mm - Ø50mm (IS)

Ø25mm (RS only)

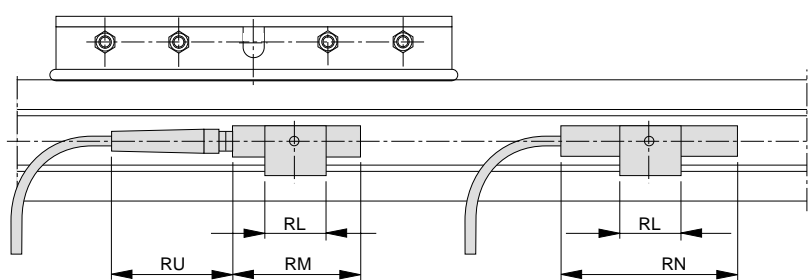

Ø32mm - 50mm

(RS version only)

Cyl. Ø	RB	RC	RL	RM	RN	RP	RQ	RS	RT	RU
10	---	.67	---	1.38	1.38	---	---	.35	.20	1.38
16	.67	1.10	.79	1.38	1.57	1.06	.43	---	---	1.38
25	.79	1.46	.79	1.38	3.15	1.32	.43	---	---	1.38
32	.98	1.72	.79	1.38	3.15	1.58	.22	.43	---	1.38
40	.98	1.91	.79	1.38	3.15	1.77	.22	.43	---	1.38
50	1.26	2.17	.79	1.38	3.15	2.03	.22	.43	---	1.38

Proximity Switch Series P120 cylinders

For non-contact sensing of piston position on Origa rodless cylinders. Note: Series P120 cylinders ordered without Reed Switches are supplied with non-magnetic pistons.

Available for use on Series P120 cylinders.

Ø 40mm, 63mm and 80mm - Switches can be mounted on both sides of cylinder upon request.

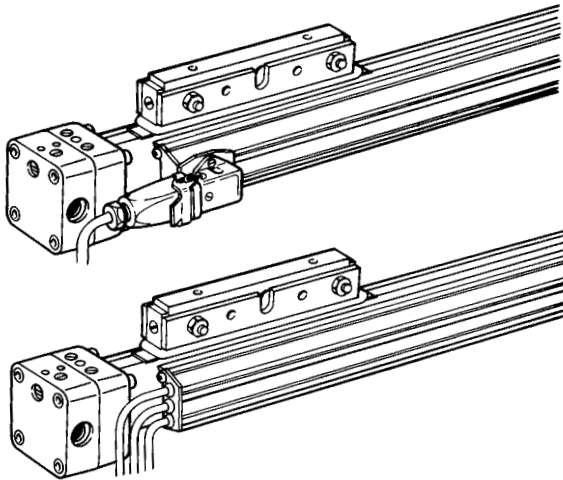

RSA: with RS (Reed Switch) ISA: with IS (Inductive Switch)

- Proximity switch connected across multi-pole connector.
- Operating points freely adjustable along the entire piston stroke length.

RSD: with RS (Reed Switch) ISD: with IS (Inductive Switch)

- Proximity switch with permanently connected cable.
- Operating points freely adjustable along the entire piston stroke length.

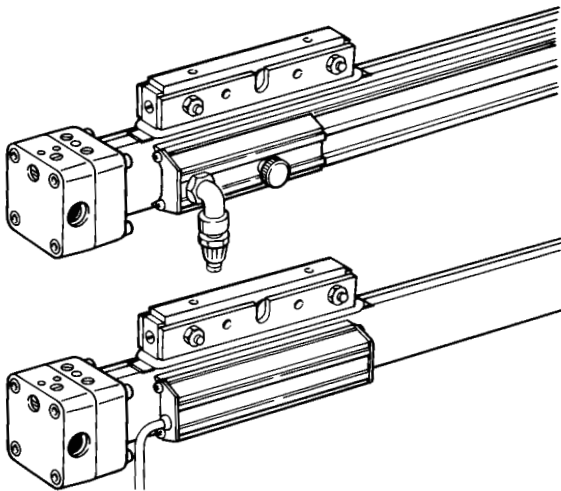

RSQ: with RS (Reed Switch) ISQ: with IS (Inductive Switch)

- Proximity switch with permanently connected cable protected by flexible conduit.
- Quick, adjustable settings along the entire piston stroke length.

RSF: with RS (Reed Switch) ISF: with IS (Inductive Switch)

- Proximity switch with permanently connected cable designed to serve as a fixed limit switch.

Advantages of Proximity Switches (RS and IS) Simple Installation

The proximity switch track is permanently fixed to the side of the cylinder barrel. The switch assemblies are installed within the track at the desired positions.

Safe in Operation

The proximity switch encapsulated in the aluminum housing has IP 65 (RS) and IP 67 (IS) protection and therefore can be used under adverse conditions.

Compact

With the switches mounted directly to the side of the barrel minimal additional space is required in terms of cylinder width. The overall length of the cylinder does not change.

Cost Effective

Eliminates the need for cam and switch mountings. Maintenance free, no wearing parts.

Type RSA/ISA

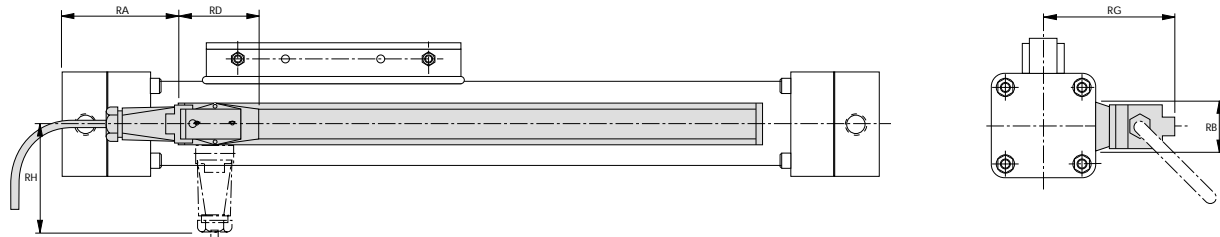

- A maximum of 6 proximity switches can be connected to each plug connection.
- The plug connection consists of a socket and plug ready for wiring.
- The plug connection is delivered assembled onto the end of the track.
- The plug connection can be mounted in 4 different directions.

Type RSD/ISD

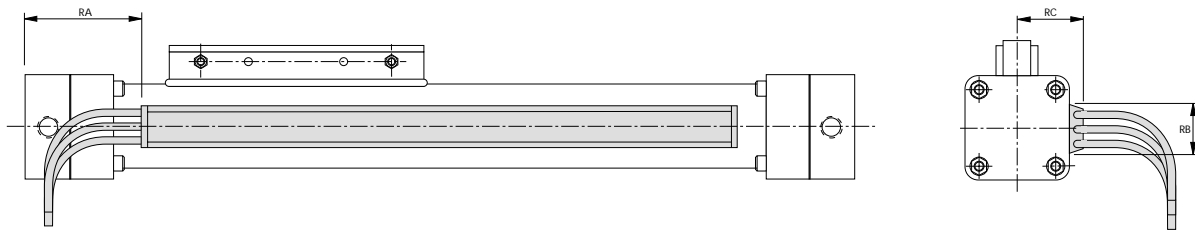

- A maximum of 6 proximity switches per switch track with cable outlet optional, 3 x left and 3 x right.
- Cable length 5 meters

Type RSQ/ISQ

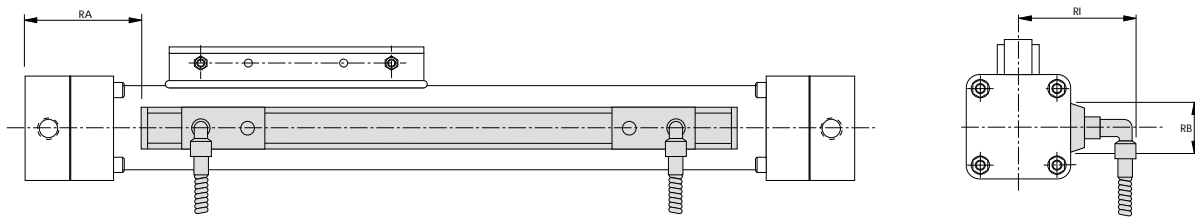

- For quick adjustment of switches.
- Optional number of switches.
- Cable length 5 meters with protective conduit.

Type RSF/ISF

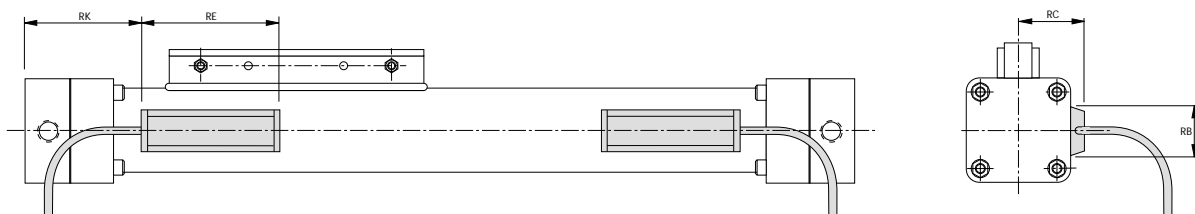

- End of stroke sensing
- Cable length 5 meters

Cyl. Ø	RA (S/)	RA (L/)	RK (S/)	RK (L/)	RB	RC	RD	RE	RG	RH	RI
40	3.35	7.28	3.46	7.40	1.69	1.93	2.05	4.53	4.06	3.54	3.07
63	4.13	10.04	5.83	11.73	1.69	2.52	2.05	4.53	4.65	3.54	3.66
80	4.92	10.83	7.40	13.31	1.69	2.99	2.05	4.53	5.12	3.54	4.13

Spare Parts

<u>Spare Part Groups</u>			<u>Page</u>
Series 2000 -	Basic Cylinder -	Ø10mm - Ø50mm	5.1/2
Series 2000 -	Piston -	Ø10mm - Ø25mm	5.1/4
Series 2000 -	Piston -	Ø32mm - Ø50mm	5.1/6
Series 2000 -	Joint Clamp -	Ø25mm - Ø50mm	5.1/8
Series 2000 -	NR50 -	Ø16mm - Ø50mm	5.1/10
Series 2000 -	Powerguide -	Ø25mm, Ø32mm, Ø50mm	5.1/12
Series P120 -	Basic Cylinder -	Ø40mm - Ø80mm	5.1/14
Series P120 -	Short Piston -	Ø40mm - Ø80mm	5.1/16
Series P120 -	Long Piston -	Ø40mm - Ø80mm	5.1/18
All Series-	Service Packs-	Ø10mm - Ø80mm	5.1/20

Spare Parts

Series 2000 - Basic Cylinder - Ø10mm - Ø50mm

Item	Description	10mm	16mm	25mm	32mm	40mm	50mm
1	Cylinder Barrel	2152-0001+S	2152-0101+S	2152-0201+S	2152-0301+S	2152-0404+S	2152-0502+S
2	Outer Band	2080-0001+S	2080-0101+S	2080-0201+S	2080-0301+S	2080-0404+S	2080-0502+S
3	Inner Band	2192-0001+S	2192-0101+S	2192-0201+S	2192-0301+S	2192-0403+S	2192-0502+S
4	End Cap - Right (B)	3016	2164-0154	2164-0258	2164-0352	2164-0456	2164-0552
4.1	End Cap - Right (V)	3028	2714-0154	2714-0258	2714-0352	2714-0454	2714-0552
5	O-Ring - Cushion Screw (B)	N/A	0766	1252-1102	1252-1102	1252-1102	1252-1102
5.1	O-Ring - Cushion Screw (V)	N/A	0767	1262-1102	1262-1102	1262-1102	1262-1102
6	Cushion Screw	N/A	0734	0409	2072-0202	2072-0202	2072-0202
7	N/A						
8	O-Ring - Cushion Pipe (B)	3023	0732	1250-0301	1250-0304	1250-0307	1250-0311
8.1	O-Ring - Cushion Pipe (V)	3029	0733	1261-0301	1261-0304	1261-0307	1261-0311
9	End Cap - Left (B)	3015	2164-0153	2164-0257	2164-0351	2164-0455	2164-0551
9.1	End Cap - Left (V)	3027	2714-0153	2714-0257	2714-0351	2714-0453	2714-0551
10*	O-Ring/Gasket End Cap (B)	N/A	N/A	3119	2060-0301	1252-0123	1252-0126
10.1*	O-Ring/Gasket End Cap (V)	N/A	N/A	2061-0201	2061-0301	1262-0123	1262-0126
11	Outer Band Lock Screws	2809	0847	1033-0304	1033-0404	1033-0404	1033-0404
12	Outer Band Lock	3022	0738	2062-0201	2062-0301	2062-0301	2062-0301
13	Inner Band Lock Screws	0846	0846	1024-0304	1024-0405	1024-0405	1024-0405
14	Inner Band Lock	3021	0736	2078-0201	2078-0301	2078-0301	2078-0501
15	End Cap Screw	0735	0735	2014-0201	2014-0351	2014-0351	2014-0551
19	Cushion Pipe	N/A	N/A	2211-0202	2211-0301	2211-0401	2211-0501
**	Service Pack-1 Piston (B)	SP10-B-1 xS	SP16-B-1 xS	SP25-B-1 xS	SP32-B-1 xS	SP40-B-1 xS	SP51-B-1 xS
**	Service Pack-1 Piston (V)	SP10-V-1 xS	SP16-V-1 xS	SP25-V-1 xS	SP32-V-1 xS	SP40-V-1 xS	SP51-V-1 xS
**	Service Pack-2 Piston (B)	SP10-B-2 xS	SP16-B-2 xS	SP25-B-2 xS	SP32-B-2 xS	SP40-B-2 xS	SP51-B-2 xS
**	Service Pack-2 Piston (V)	SP10-V-2 xS	SP16-V-2 xS	SP25-V-2 xS	SP32-V-2 xS	SP40-V-2 xS	SP51-V-2 xS
	Seal Kit-1 Piston (B)	2790-0001	2790-0101	2790-0202	2790-0301	2790-0402	2790-0502
	Seal Kit-1 Piston (V)	2791-0001	2791-0101	2791-0202	2791-0301	2791-0402	2791-0502
	Seal Kit-2 Piston (B)	2790-0001-2	2790-0101-2	2790-0202-2	2790-0301-2	2790-0402-2	2790-0502-2
	Seal Kit-2 Piston (V)	2791-0001-2	2791-0101-2	2791-0202-2	2791-0301-2	2791-0402-2	2791-0502-2

(B) = Buna-N

(V) = Viton

*Note: Ø25mm - Ø50mm cylinders have a two-part end cap/cushion pipe assembly.
A gasket (Ø25mm - Ø32mm) or O-Ring (Ø40mm - Ø50mm) is fitted between the two parts.
(These components are not shown in the illustration on page 5.1/3)

**Note: Please identify stroke "S" required when ordering.

Series 2000

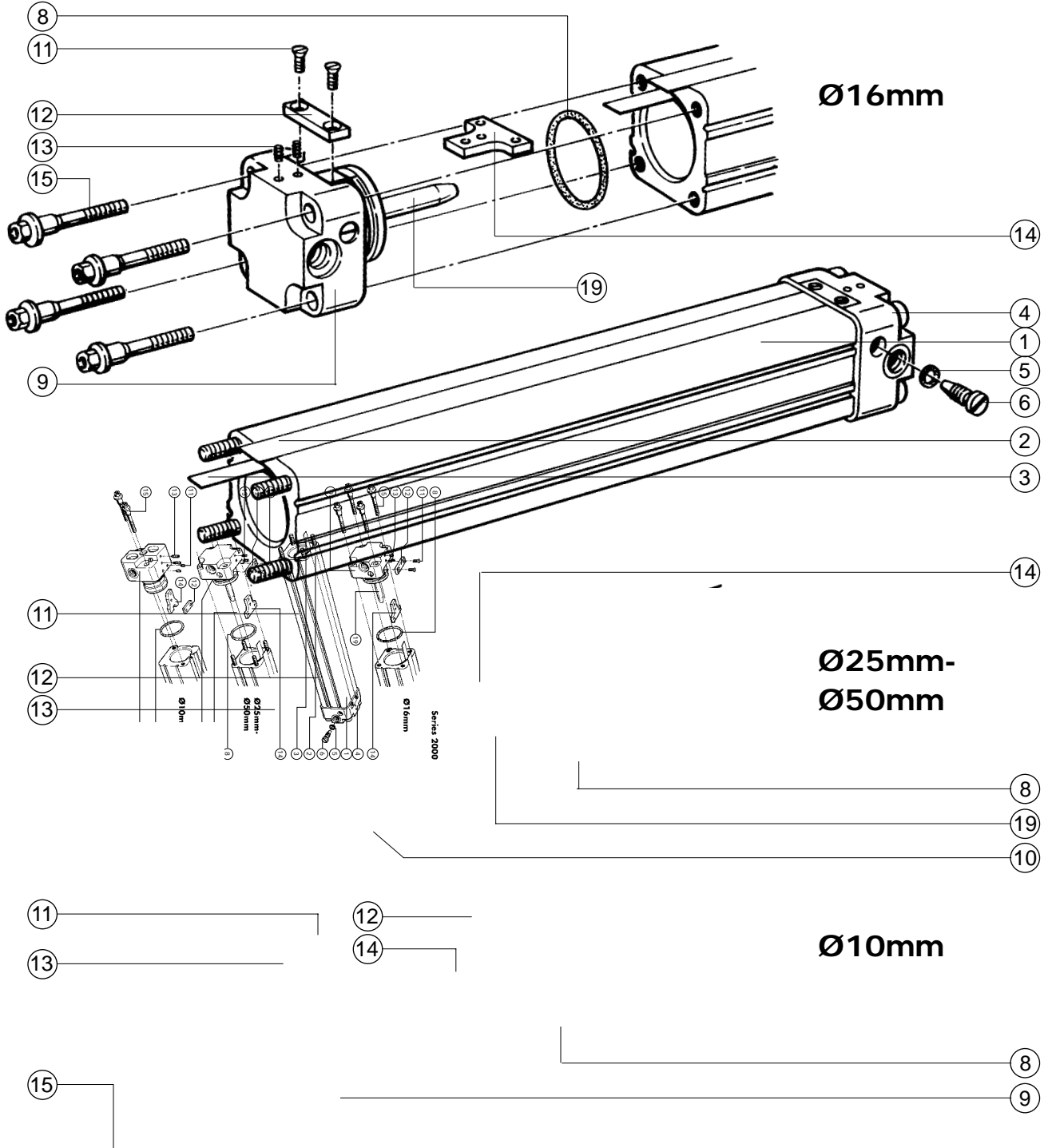

Spare Parts

Series 2000 - Piston - Ø10mm - Ø25mm

Item	Description	10mm	16mm	25mm
20	Piston Seal (B)	3035	0745	2050-0201
20.1	Piston Seal (V)	3096	0746	2052-0201
21	Cushion Seal (B)	N/A	0751	2054-0201
21.1	Cushion Seal (V)	N/A	0752	2056-0201
22*	Complete Piston	3053	1853	0896
23	Screw - Piston Mount	3583	0754	2702
24	Bearing Strip	2798-0001	2798-0101	2798-0202
25	Nut - Piston Mount	N/A	0796	N/A
26	Scraper	2238-0001	2238-0101	0155
27	Piston Mount - NR20	3052	1815	0898
28	Bracket - NR25 Mount	N/A	N/A	2115-0202
29	Fork Bracket	3056	0758	2120-0202
31	O-Ring - Yoke (B)	N/A	0747	1045
31.1	O-Ring - Yoke (V)	N/A	0748	1046
39	Carrier Pin			

(B) = Buna-N

(V) = Viton

Note: Ø25mm cylinders purchased after 1994 with floating mount NR25, utilize items 28, 29, 33 and 39 detailed on page 5.1/7.

*Note: P/N: 0896 refers to new piston design introduced 10/94. Consult factory for earlier constructed cylinders.

Spare Parts

Series 2000 - Piston - Ø32mm - Ø50mm

Item	Description	25mm	32mm	40mm	50mm
20	Piston Seal (B)		2050-0301	2050-0403	2050-0502
20.1	Piston Seal (V)		2052-0301	2052-0401	2052-0502
21	Cushion Seal (B)		1235-1000	1235-1200	1235-1600
21.1	Cushion Seal (V)		1236-1000	1236-1200	1236-1600
22	Complete Piston		2664-0302	2664-0404	2664-0502
23	Screw - Piston Mount		1008-0517	1008-0517	1008-0517
24	Bearing Strip		2798-0301	2798-0402	2798-0501
25	Nut - Piston Mount		1046-0500	1046-0500	1046-0500
26	Scraper		2238-0301	2238-0301	2238-0501
27	Piston Mount - NR20		2110-0351	2110-0351	2110-0552
28	Bracket - NR25 Mount	2115-0202	2115-0301	2115-0301	2115-0501
29	Fork Bracket	2120-0202	2120-0301	2120-0301	2120-0501
30	O-Ring - Yoke (B)		1270-0253	1270-0253	1270-0265
30.1	O-Ring - Yoke (V)		1261-0253	1261-0253	1261-0265
31	Tension Pin		1108-0532P	1108-0532P	1108-0532P
33	Screw - NR25 Mount	1000-0506	1004-0710	1004-0710	1004-0912
39	Carrier Pin	2786-0202	2786-0301	2786-0301	2786-0501

(B) = Buna-N

(V) = Viton

Series 2000

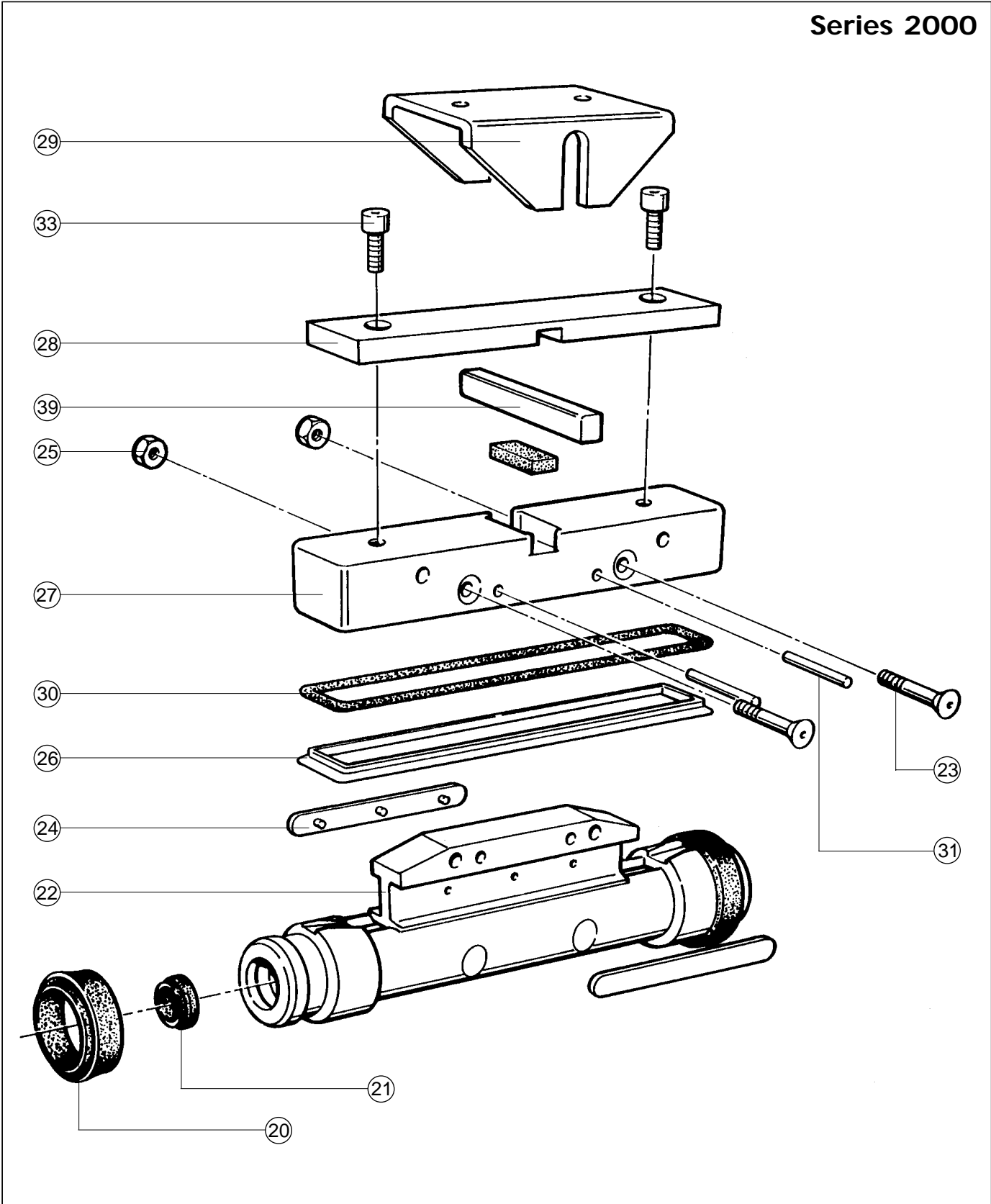

Spare Parts

Series 2000 - Joint Clamp - Ø25mm - Ø50mm

Item	Description	25mm	32mm	40mm	50mm
1	Cylinder Barrel	2152-0201+S	2152-0301+S	2152-0404+S	2152-0502+S
2	Outer Band	2080-0201+S	2080-0301+S	2080-0404+S	2080-0502+S
3	Inner Band	2192-0201+S	2192-0301+S	2192-0403+S	2192-0502+S
5	O-Ring - Cushion Screw (B)	1252-1102	1252-1102	1252-1102	1252-1102
5.1	O-Ring - Cushion Screw (V)	1262-1102	1262-1102	1262-1102	1262-1102
6	Cushion Screw	2072-0202	2072-0202	2072-0202	2072-0202
16	Joint Clamp Rail - NR6	2746-0201+S	2746-0301+S	2746-0401+S	2746-0502+S
17	Screw - Joint Clamp Rail	1000-0314	1000-0315	1000-0317	1000-0517
18	Connection Pipe	2774-0201	2774-0301	2774-0301	2774-0501

(B) = Buna-N

(V) = Viton

Series 2000

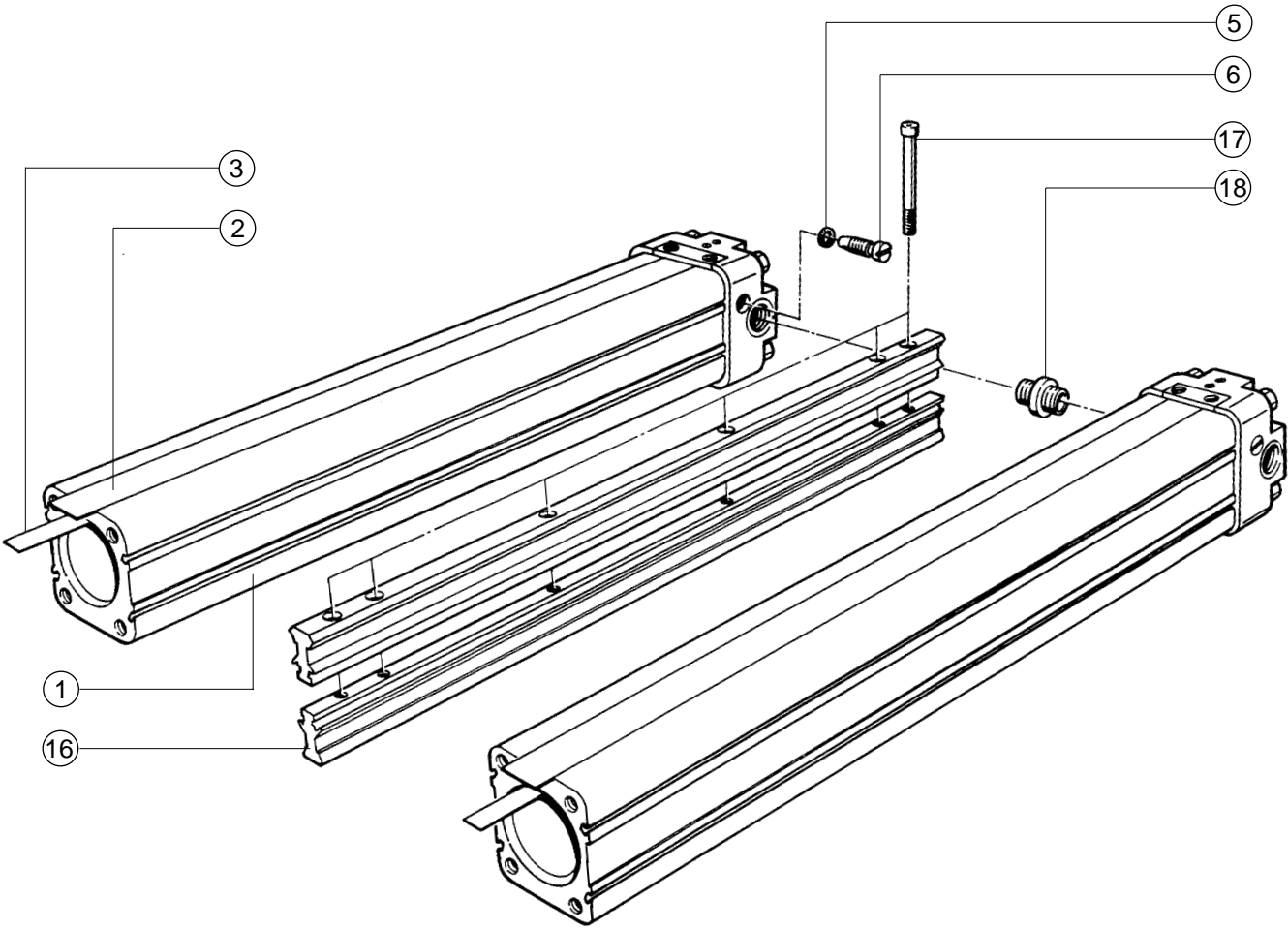

Spare Parts

Series 2000 - NR50 - Ø16mm - Ø50mm

Item	Description	16mm	25mm	32mm	40mm	50mm	
45	Link Plate	3328	2845-0201	2845-0301	2845-0401	2845-0501	
45.1*	Link Plate	N/A	2845-0202	2845-0302	2845-0402	2845-0502	
46	Guide Rail	3265	2263-0201	2263-0301	2263-0401	2263-0501	
47	End Plate	3323	2847-0201	2847-0301	2847-0401	2847-0501	
47.1*	End Plate	N/A	2847-0201	2847-0302	2847-0402	2847-0502	
48	Connection Plate	3331	2846-0201	2846-0301	2846-0301	2846-0501	
49	Screw - Guide Rail Clamp	3306	1000-0315	1000-0416	1000-0418	1000-0518	
50	Guide Rail Clamp	2227-0101	2227-0201	2227-0301	2227-0301	2227-0501	
51	Adjustment Screw	1041	1020-0506	1020-0506	1020-0506	1020-0506	
51.1*	Adjustment Screw	N/A	1020-0406	1020-0406	1020-0406	1020-0506	
52	Bearing Strips/Pressure Plates	2799-0101	2799-0201	2799-0301	2799-0401	2799-0501	
52.1*	Bearing Strips/Pressure Plates	N/A	2799-0202	2799-0302	2799-0402	2799-0502	
53	Screw - End Plate	3278	1036-0305	1036-0406	1036-0406	1036-0406	
54	Screw - Connection Plate	3307	1016-0516	1016-0618	1016-0618	1016-0819	
55	Shuttle	3321	2842-0201	2842-0351	2842-0451	2842-0551	
55.1*	Shuttle	N/A	2842-0252	2842-0352	2842-0452	2842-0552	
56	Lock Nut	N/A	1040-0500	1040-0500	1040-0500	1040-0500	
56.1*	Lock Nut	N/A	1040-0400	1040-0400	1040-0400	1040-0500	
**	Conversion Kit	N/A	2660-0252	2660-0352	2660-0452	2660-0552	

(B) = Buna-N

(V) = Viton

*Cylinders supplied after 06/94 are fitted with these updated items.

**Conversion of old style NR50 shuttle to new style NR50 shuttle, replacing items 45, 47, 48, 51, 52, 53, 54, 55 and 56 can be accomplished using the "Conversion Kit" part numbers detailed above.

Spare Parts

Series 2000 - Powerguide™ - Ø25mm, 32mm, Ø50mm

Item	Description	25mm	32mm	50mm
1	Carriage Plate	USCP-25/25	USCP-32/44	USCP-50/76
2	Concentric Journal	4007	4015	OSJ-54-C
3	Eccentric Journal	4008	4016	OSJ-54-E
4	Journal Cap Seals	4009	4017	OCS-54
5	Slide Plate	3462	3482	C-50/76
6	Back Plate	3461	3481	BP-50/76
7	Drive Block	4006	4014	SDB-50/76
8	Screw	0163	1000-0616	1006-0913
8.1	Screw, stainless steel	0164	1002-0616	1006-0913
9	Screw	4042	4043	9427-1020
9.1	Screw, stainless steel	N/A	N/A	N/A
10	Screw	Included in Item No. 4		
11	Washer	Included in Item No. 4		
12	Location Bracket	4005	4013	SLB-50/76
13	Countersunk Screw	4011	1323	N/A

Spare Parts

Series P120 - Basic Cylinder - Ø40mm - Ø80mm

Item	Description	40mm	63mm	80mm
1	Cylinder Barrel S/	2152-0403+S	2152-0602+S	2152-0801+S
1.1	Cylinder Barrel L/	2153-0452+S	2153-0651+S	2153-0851+S
1.2	Magnet Strip	2244+0401+S	2244-0601+S	2074-0801
2	Outer Band S/	2080-0403+S	2080-0603+S	2080-0801+S
2.1	Outer Band L/	2081-0451+S	2081-0651+S	2081-0851+S
3	Inner Band S/	2192-0402+S	2192-0602+S	2192-0802+S
3.1	Inner Band L/	2193-0451+S	2193-0652+S	2193-0851+S
4	End Cap - Right (B)	2164-0454-R	2164-0654-R	2164-0852-R
4.1	End Cap - Right (V)	2714-0452-R	2714-0652-R	2714-0851-R
5	O-Ring - Cushion Screw (B)	1252-0101	1252-0101	1252-0101
5.1	O-Ring - Cushion Screw (V)	1262-0101	1262-0101	1262-0101
6	Cushion Screw	2072-0301	2072-0601	2072-0601
7	Lock Ring - Upper/Lower	2012-0404	2012-0604	2012-0802
8	Screw - End Cap	1004-0718	1004-0920	1004-1124
9	Cap Ring	2008-0406	2008-0606	2008-0802
10	O-Ring - End Cap (B)	1250-0307	1250-0503	1250-0506
10.1	O-Ring - End Cap (V)	1261-0307	1261-0503	1261-0506
11	End Cap - Left (B)	2164-0454-L	2164-0654-L	2164-0852-L
11.1	End Cap - Left (V)	2714-0452-L	2714-0652-L	2714-0851-L
12	Inner Band Lock Set	2078-0403	2078-0603	2078-0803
13	Screw - Inner Band Lock	1024-0605	1024-0605	1024-0807
14	Plug - Cap Ring	2068-0401	2068-0401	2068-0401
15	Screw - Outer Band Lock	1033-0505	1033-0506	1033-0506
16	Outer Band Lock	2062-0401	2062-0401	2062-0401
**	Service Pack-Short Piston (B)	SP124-B-S xS	SP126-B-S xS	SP128-B-S xS
**	Service Pack-Short Piston (V)	SP124-V-S xS	SP126-V-S xS	SP128-V-S xS
**	Service Pack-Long Piston (B)	SP124-B-L xS	SP126-B-L xS	SP128-B-L xS
**	Service Pack-Long Piston (V)	SP124-V-L xS	SP126-V-L xS	SP128-V-L xS
	Seal Kit-Short Piston (B)	2790-0401	2790-0601	2790-0801
	Seal Kit-Short Piston (V)	2791-0401	2791-0601	2791-0801
	Seal Kit-Long Piston (B)	2792-0401	2792-0601	2792-0801
	Seal Kit-Long Piston (V)	2793-0401	2793-0601	2793-0801

(B) = Buna-N

(V) = Viton

**Note: Please identify stroke "S" required when ordering.

Series P120

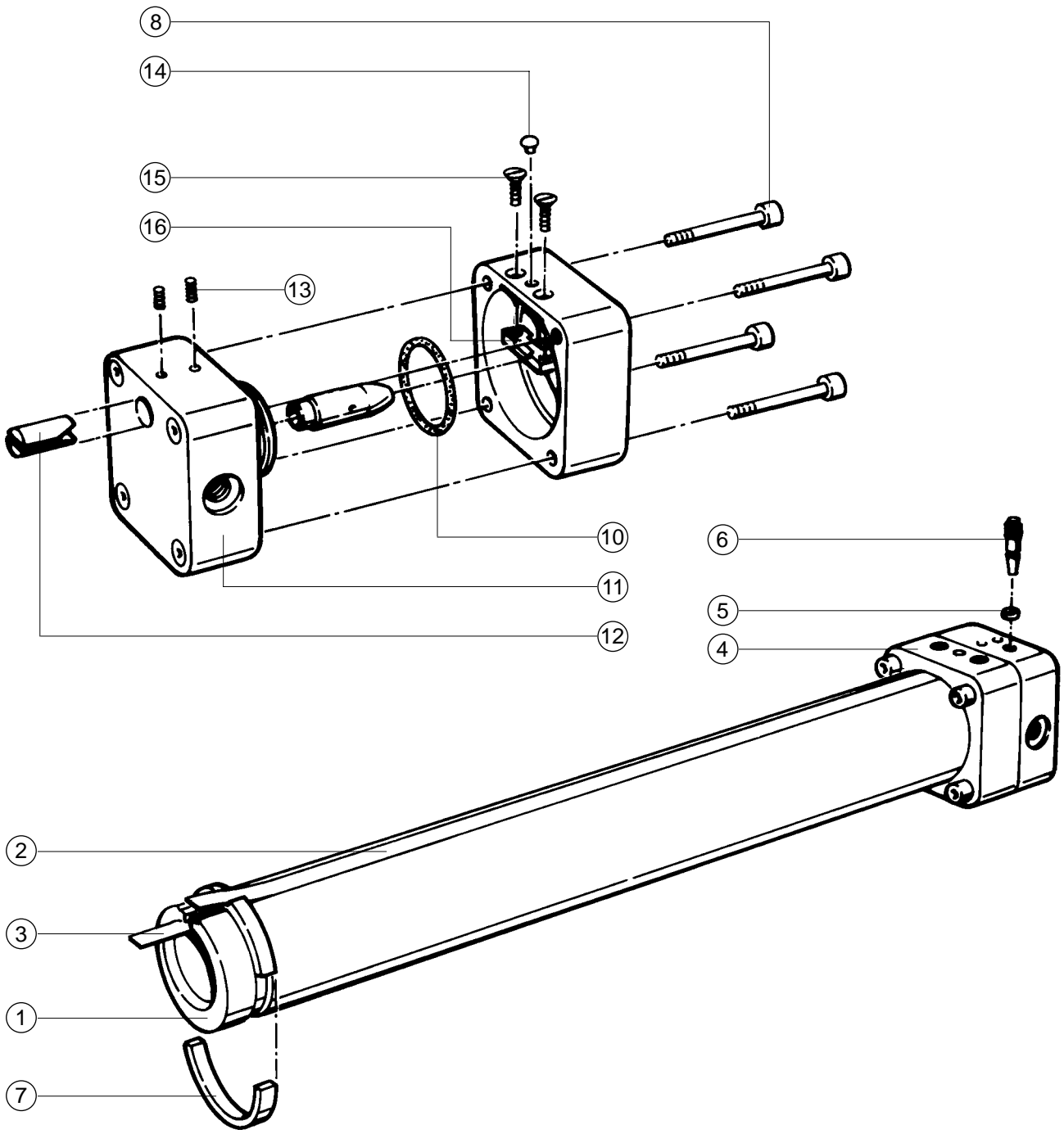

Spare Parts

Series P120 - Short Piston - Ø40mm - Ø80mm

Item	Description	40mm	63mm	80mm
20	Piston Seal (B)	2050-0403	2050-0603	2050-0802
20.1	Piston Seal (V)	2052-0401	2052-0601	2052-0801
21	Bearing Ring	2042-0402	2042-0602	2042-0801
22	Cushion Seal (B)	2054-0403	2054-0604	2054-0802
22.1	Cushion Seal (V)	2056-0403	2056-0604	2056-0802
23	Screw - Yoke	1000-0612	1000-0816	1000-0818
24	Piston Axle (non-magnetic) S/	2154-0404	2154-0604	2154-0802
24.1	Piston Axle (magnet 1 side) S/	N/A	2664-0602	2664-0802
25	Piston Axle (magnet 2 side) S/	2664-0402	2664-0602/D	2664-0802/D
26	Nut - Piston Mount	1040-0600	1040-0800	1040-1000
27	Piston Yoke	2031-0403	2031-0603	2031-0801
28	Bearing Strip	2798-0401	2798-0601	2798-0801
29	Screw - Piston Mount	1000-0616	1000-0816	1000-1018
30	Screw - Piston Mount End	1038-0507	1038-0507	1038-0507
31	Scraper	2067-0403	2067-0602	2067-0801
32	Piston Mount End Plate	2040-0404	2040-0604	2040-0801
33	Piston Mount - S/20	2778-0401	2778-0601	2778-0801
34	Piston Mount - S/22	2782-0401	2782-0601	2782-0801
35	Piston Mount - S/25	2186-0404	2186-0604	2186-0802
36	Fork Bracket	2120-0401	2120-0601	2120-0802
37	Carrier Pin	2122-0401	2122-0601	2122-0801
38	O-Ring - Yoke (B)	1272-0510	1272-0518	1272-0524
38.1	O-Ring - Yoke (V)	1262-0510	1262-0518	1262-0524

(B) = Buna-N

(V) = Viton

Series P120

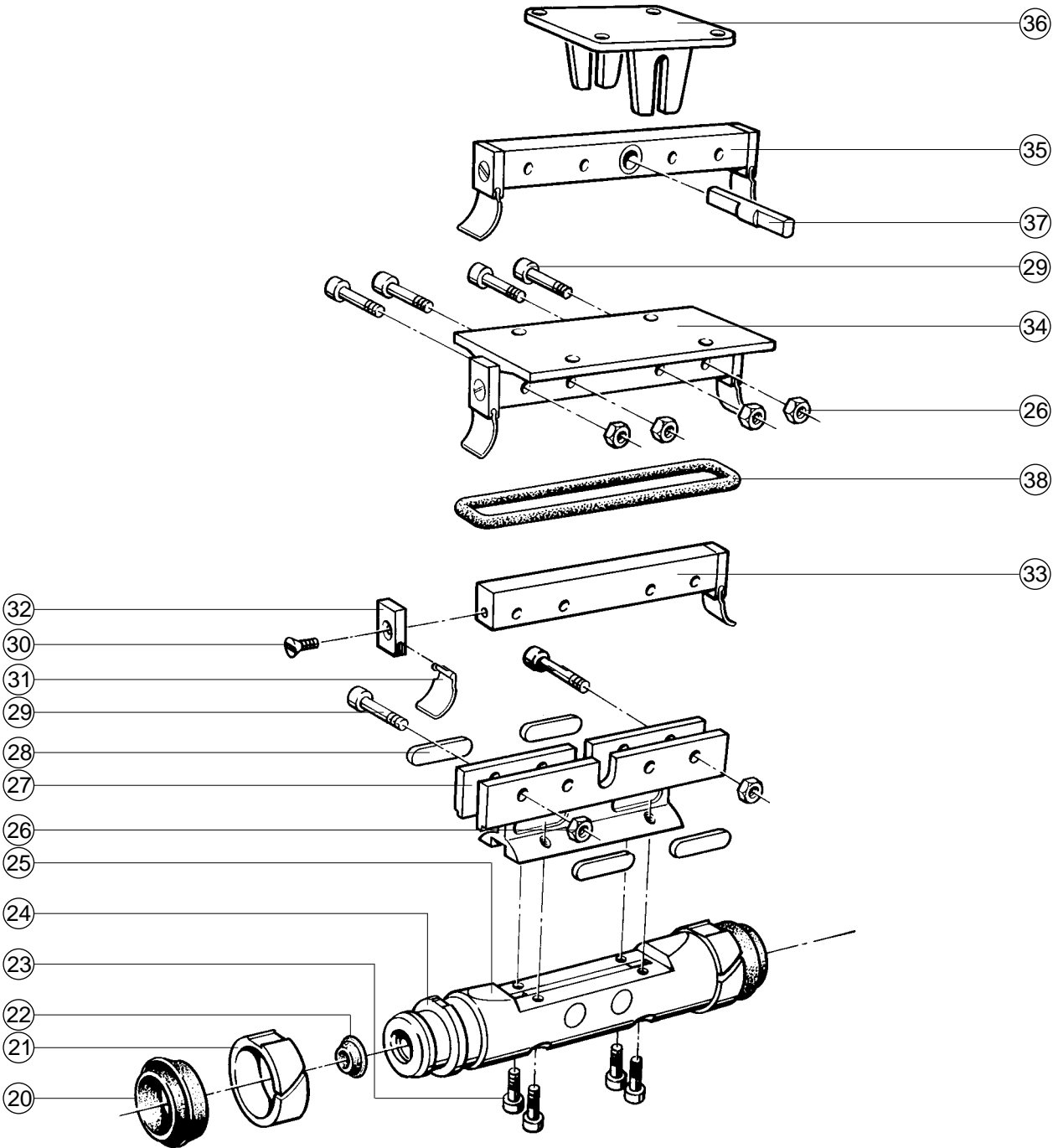

Spare Parts

Series P120 - Long Piston - Ø40mm - Ø80mm

Item	Description	40mm	63mm	80mm	
20	Piston Seal (B)	2050-0403	2050-0603	2050-0802	
20.1	Piston Seal (V)	2052-0401	2052-0601	2052-0801	
21	Bearing Ring	2042-0402	2042-0602	2042-0801	
22	Cushion Seal (B)	2054-0403	2054-0604	2054-0802	
22.1	Cushion Seal (V)	2056-0403	2056-0604	2056-0802	
23	Screw - Yoke	1000-0612	1000-0816	1000-0818	
26	Nut - Piston Mount	1040-0600	1040-0800	1040-1000	
28	Bearing Strip	2798-0401	2798-0601	2798-0801	
29	Screw - Piston Mount	1000-0616	1000-0816	1000-1018	
30	Screw - Piston Mount End	1038-0507	1038-0507	1038-0507	
31	Scraper	2067-0403	2067-0602	2067-0801	
32	Piston Mount End	2040-0404	2040-0604	2040-0801	
40	Piston Axle (non-magnetic) L/	2156-0452	2156-0652	2156-0852	
40.1	Piston Axle (magnet 1 side) L/	N/A	2666-0651	2666-0851	
41	Piston Axle (magnet 2 side) L/	2666-0451	2666-0651/D	2666-0851/D	
42	Piston Yoke	2033-0403	2033-0603	2033-0801	
43	Piston Mount - L/26	2780-0401	2780-0601	2780-0801	
44	Piston Mount - L/28	2784-0401	2784-0601	2784-0801	
45	O-Ring - Yoke (B)	1272-0526	1272-0538	1272-0542	
45.1	O-Ring - Yoke (V)	1262-0526	1262-0538	1262-0542	

(B) = Buna-N

(V) = Viton

Series P120

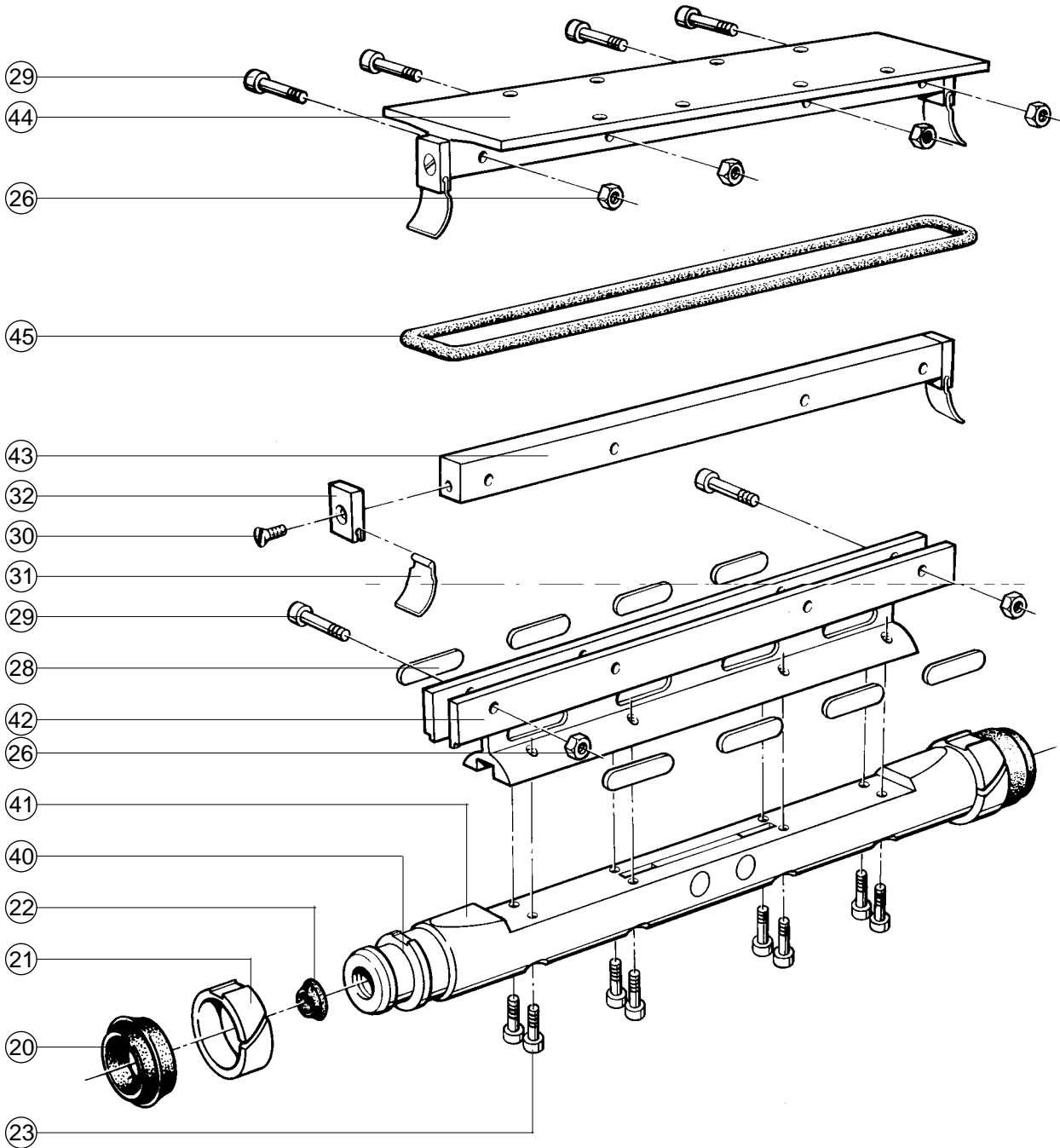

Spare Parts

Service Packs - Series 2000 / Series P120 - All bore sizes.

Designation		Bore Sizes					
Series 2000		10mm	16mm	25mm	32mm	40mm	50mm*
Buna-N Service Pack	Part Number	SP10-B-1	SP16-B-1	SP25-B-1	SP32-B-1	SP40-B-1	SP51-B-1
Single Piston							
Viton Service Pack	Part Number	SP10-V-1	SP16-V-1	SP25-V-1	SP32-V-1	SP40-V-1	SP51-V-1
Single Piston							
Buna-N Service Pack	Part Number	SP10-B-2	SP16-B-2	SP25-B-2	SP32-B-2	SP40-B-2	SP51-B-2
Double Piston							
Viton Service Pack	Part Number	SP10-V-2	SP16-V-2	SP25-V-2	SP32-V-2	SP40-V-2	SP51-V-2
Double Piston							

*Use SP50... for 2020 (old style) versions of 50mm cylinders only.

Designation		Bore Sizes		
Series P120		40mm	63mm	80mm
Buna-N Service Pack	Part Number	SP124-B-S	SP126-B-S	SP128-B-S
Short Piston				
Viton Service Pack	Part Number	SP124-V-S	SP126-V-S	SP128-V-S
Short Piston				
Buna-N Service Pack	Part Number	SP124-B-L	SP126-B-L	SP128-B-L
Long Piston				
Viton Service Pack	Part Number	SP124-V-L	SP126-V-L	SP128-V-L
Long Piston				

Service Pack Information

Service Packs, containing all the components necessary to completely rebuild an Origa rodless cylinder, are available. Each pack contains a complete seal kit, inner and outer bands, Origa grease tube, cleaning tool and repair instructions. It's all packaged in an easy-to-ship, easy-to-store box clearly labeled to indicate the cylinder type, bore and stroke it is intended for. Contact your local Origa distributor for more information.

Ordering Information

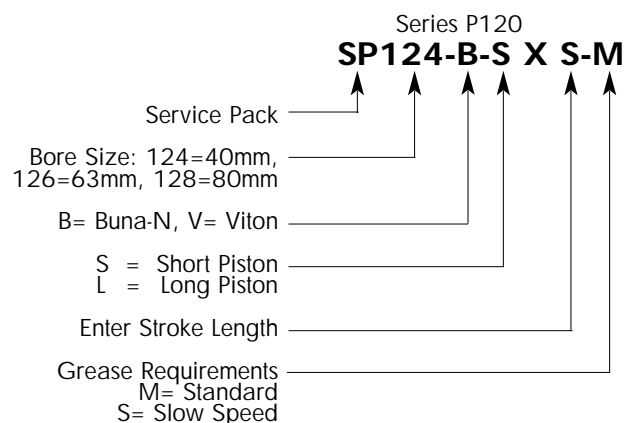
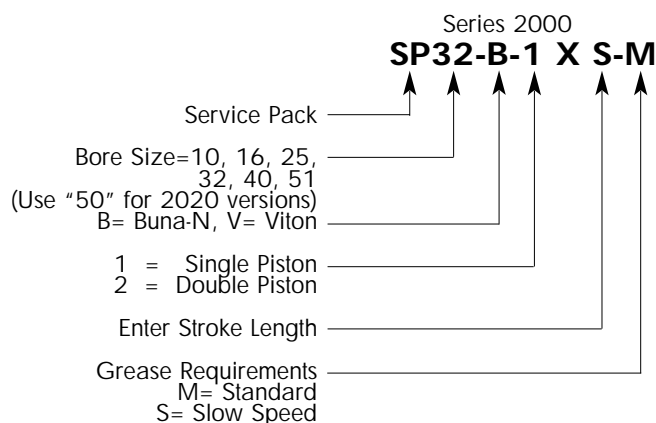

Assembly Instructions



Cylinder Types

Page

Series 2000 -	Basic Cylinder -	Ø10mm - Ø50mm	6.0/2 - 6.0/3
Series P120 -	Basic Cylinder -	Ø40mm - Ø80mm	6.0/2 - 6.0/3
Series 2000 -	Powerguide™ -	Ø25mm - Ø50mm	6.0/4 - 6.0/5
Series 2000 -	NR50 -	Ø16mm - Ø50mm	6.0/6 - 6.0/7
All Series -	Service Packs -	Ø10mm - Ø80mm	6.0/8

Assembly Instructions (Series P120, Series 2000)

Typified by ideally matched materials and fully developed design details, Origa cylinders have a very long operational life. However, the service life may be reduced by extreme and demanding environmental conditions, therefore occasional maintenance is recommended.

Dismantling of the cylinder

Comply with local safety regulations:

1. Disconnect air and electrical supplies.
2. Remove cylinder from framework.
3. Remove piston mounting
4. Remove outer band by removing band locking screws at each end.
5. Loosen inner band locking screws at each end.
6. Remove screws, nuts and bolts at each end.
7. Gently remove end caps - avoid tilting.
8. For series **P120**. Push inboard cap rings. Remove locking rings and slide the cap ring off the barrel.
9. Slide out piston and inner band (4). Use caution when handling the inner band - edges are sharp.

Inspection

1. Clean and inspect all parts
 - seals for wear.
 - bands for nicks and dents
 - tube for wear along the slot and damage to the bore.
2. Replace worn parts.

Pre-Assembly

1. Apply ample grease to seals and O-rings.
2. Lightly grease cylinder bore with grease.
3. Ensure that all bearing rings/piston ends and bearing strips are in position.

Assembly

1. Insert inner band into the bore with the band washer facing up towards the slot.
2. Draw sufficient band out to thread through the piston, slide the piston into the bore and move to a mid-stroke position.

Note: A very small piece of old inner band can be used as a threading strip. Additionally, bend up the first 20mm of band to approx. 30°. This will allow the band to pass freely through the piston.

3. Pull the inner band through until evenly positioned in the tube.
4. For series **P120**. Fit cap rings lock rings outer band locks fit end cap and tighten retaining screws.
5. Check that the inner band washers are visible through the cap ring top center hole.
6. Fit inner band locks.
7. Tighten inner band lock screws on one end only.
8. Insert a small screwdriver through the cap rings top center hole. Gently apply leverage to remove any slackness in the band. Release and tighten the remaining inner band lock screws.

Series 2000

9. Fit end caps
10. Check inner band washer up to one end cap. Tighten locking screws.
11. At the opposite end use a small screwdriver, gently push the inner band washer towards the end cap. Release and tighten the locking screws.

Series P120

12. Check that the inner band is laying smooth and that there is no sag. Note: to check for proper tension, depress the band through the slot about 3/16", ensure that it springs back.
13. Fit the outer band and the piston mounting. Tighten the locking screws on the mounting and then each end cap.
14. Fit yoke/mounting O-ring.
15. Manually move the piston through it's full stroke to insure there is no resistance to it's movement.

Cleaning if inner band (use eye protection)

During assembly dirt particles may become lodged between the sealing band and the cylinder tube contact surfaces. These particles can cause leaks and must be removed.

1. Remove mounting and outer band.
2. Apply 30 PSI (2 bar) air pressure.
3. Insert cleaning tool into the slot and depress where it is leaking. The expelled air will "blow out" any foreign particles, if present.
4. When complete, reinstall the outer band and mounting

Note:

If the band continues to leak a full cylinder inspection is recommended.

Defect Diagnosis

Defect	Cause	Correction
Audible leak in stopped position	Leakage at inner band due to dirt	Clean inner band with LRF cleaning tool
	Leakage at inner band due to abrasion	Replace inner band
	Leakage at end cap	Replace end cap O-ring
	Leakage at piston	Replace piston seals
Cylinder speed is inconsistent	Insufficient lubrication	Relubricate
	Piston seals worn out	Replace piston seals
Cylinder impacts in end position	Overloaded	Reduce overload or install hydraulic shocks
	Incorrect setting of cushion screws	Reset
	Insufficient buildup of backpressure	Install flow controls or readjust existing ones
	Cushion seal defect	Replace cushion seals

Assembly Instructions - Powerguide™

Repair the basic cylinder as per Series P120/Series 2000 assembly instructions.

Slide system adjustment

Important:- Excessive pre-load must not be applied during the adjustment process.

All Powerguide™ components associated with the slide system are factory set prior to delivery and should not require adjustment. If however, play should occur requiring re-adjustment the following procedure should be followed:

1. Remove non-Powerguide™ components attached to carriage plate **(1)**.
2. Remove one of the drive blocks **(7)** to free the carriage assembly.
3. Remove the complete carriage assembly from the slide **(5)**.
4. Remove cap seals **(4)** and return carriage assembly to the slide.
5. Slacken eccentric bearing assembly fixing nuts **(3)** slightly using a socket.
25 Dia. Size 13mm
32 Dia. Size 17mm
50 Dia. Size 22mm
6. Rotate each eccentric bearing assembly **(3)** using the special wrench until play is removed taking care to induce only minimal pre-load. Re-tighten fixing nuts whilst preventing the eccentric stud from rotating using the special wrench.

7. Check one of each pair of opposing bearing assemblies for correct pre-load by rotating the bearings between forefinger and thumb so that the bearing skids against the slide. A degree of resistance should be felt, but the bearings should rotate without difficulty.
8. Remove carriage assembly from the slide and refit cap seals.
9. Return carriage assembly to the slide and adjust cap seals to just make contact with the slide until smearing of the lubricant is observed whilst operating.
NB: Excess adjustment will result in increased friction.
10. Replace drive block and adjust for no play condition against location bracket.
11. Re-lubricate cap seals according to "lubrication instructions".

Powerguide™ Part No	Special Wrench
25-2021/PG	AT 25
32-2020/PG	AT 34
50-2020/PG	AT 54

Addendum

The following is an update to the information contained within this catalog

Page	Correction												
3.5/3	Referencing the drawing for "Piston Mounting S/20" the values for dimensions "X" and "Z" are as follows. <table border="1" data-bbox="503 661 966 829"> <thead> <tr> <th>Bore</th> <th>X</th> <th>Z</th> </tr> </thead> <tbody> <tr> <td>40mm</td> <td>3.54"</td> <td>M6</td> </tr> <tr> <td>63mm</td> <td>5.51"</td> <td>M8</td> </tr> <tr> <td>80mm</td> <td>7.09"</td> <td>M10</td> </tr> </tbody> </table>	Bore	X	Z	40mm	3.54"	M6	63mm	5.51"	M8	80mm	7.09"	M10
Bore	X	Z											
40mm	3.54"	M6											
63mm	5.51"	M8											
80mm	7.09"	M10											
5.1/4	The part number for Item 29, 10mm bore cylinder has been changed to 3033.												
5.1/7	The tension pins (item 31) have been eliminated from all Series 2000 cylinders and are no longer required.												
5.1/11	When ordering item 50, both the top and bottom rails are included.												
5.1/16	When ordering item 33, items 30 and 32 are included as an assembly.												